

Study of Galileo's Plane Using Educational Robotics

Marcelo H. Stoppa

Industrial Mathematics, Federal University of Catalão,
Catalão, Goiás, Brazil

Alessandro Carneiro

Dept. of Physics, Federal University of Catalão,
Catalão, Goiás, Brazil

Abstract

In this work is presented a discussion about the Galileo's inclined plane showing aspects from its evolution and scientific development together with a didactical proposal to teaching move concepts from learning sciences. After an introduction of physicalmathematics concepts, it is showing the construction of an experimental apparatus with Mindstorms NXT LEGO® pieces and light sensors to measure time steps in mechanical experiments. The experiment consists of measuring the time of rolling a ball along a plane with different degrees of inclination. The getting and analysis of space and time data allow an assessment of the movement. The experimental setup allows a direct comparison between Newtonian mechanics considering the existence of a pure rolling (without sliding) showing the friction force as a precursor of the rotation of the sphere with the equation of uniform motion (without bearing). The comparison suggests that there is no pure rolling. Taking into account the easy handling of the equipment involved and the method used, it is believed that he can help spread the use of technology in teaching Physics.

Keywords: Kinematics; Galileo's Plane; Educational Robotics; Mindstorms NXT®;

1. Introduction

The natural phenomenon of bodies in free fall has generated historical and philosophical discussions about Galileo's true intention with his famous experiments with inclined plane. However, its importance goes beyond the discussions because it is an excellent educational approach that allows different experimental and mathematical applications in science education. The records of important contributions to the study of the fall of bodies date back to the works of Aristotle (384-322 BC) in ancient Greece, going through the Middle Ages and coming to the works of Galileo in the Renaissance. Nevertheless, it was only between the fifteenth and sixteenth centuries, almost two thousand years after Aristotle, and after numerous contributions, that a great advance was made by the Italian philosopher and astronomer Galileo Galilei in demonstrating how to describe the mathematical principles of the movement of bodies such like rolling balls and falling objects. Understanding the Aristotle's mistakes, Galileo abandons speculative science to be the first to link theory to experiment and mathematics to physical analysis, along with abstract experiments (Drake, 1978; Galileo, 1914).

Galileo wanted to know the laws that govern the movements, especially the one of the fall of the bodies. But in this type of movement, objects move very quickly make it impossible to understand in a natural way. Moreover, at that time, Galileo did not have an instrument to measure relatively short times. It means that initially he intended only to demystify some of the Aristotle's hypotheses, for example, that the velocity of a body in fall free would be proportional to its weight. Thus, if a weight were 10 times higher it should fall 10 times faster, a fact that was not observed by many of Galileo's predecessors. However, the supposed experiments of the tower of Pisa would be useless given the brevity of the fall. In the case of objects of different densities the results could give reason to Aristotle through the senses (William, 1995).

Aristotle's ideas had already been criticized, but not to the point of being refuted. Thus, Galileo decided to confront them in the experimental part, where there would be no way to challenge their failures. From this it was understood that the weight should not have any influence on the speed of fall and that the air resistance is influenced by factors such as the shape and weight of the material of the thrown bodies and therefore idealized that, neglecting the air resistance, all bodies, regardless of weight, would fall with the same constant acceleration.

This thinking consists of another particular contribution of Galileo to the science that still holds true, that is, the possibility of performing "mental experiments or abstractions" where situations difficult or impossible to verify are proposed and concluded rationally (Galileo, 1914). In fact, Drake (1980) strongly suggests the use of abstract experiments by Galileo, whereby he would have enunciated, for example, the first principles of inertia and also emphasizes as practically certain that, in the case of the law of falling bodies, Galileo starts from the law to later carry out the experiment, and not otherwise.

Thus, Galileo looks like unhappy with the results obtained through the "Pisa Tower experiment" and need to design an alternative to investigate the movement of falling bodies. To do this, he developed an apparatus named an inclined plane, capable of delaying the fall of a sphere and an ingenious "water clock" to measure time units related to the distance traveled. The inclined plane consists of a grooved plank on which a sphere is rolled down. Both the sphere and the channel were carefully constructed to reduce friction. For more than 20 years, Galileo has refined his experiences to come to the law that states that in vacuum all bodies, regardless of weight, shape or specific density, are uniformly accelerated in the same way (Favaro, 1938). The experiments involving the Leaning Tower and spheres on an inclined plane are described in detail by Galileo in his famous work "Discourse and mathematical demonstrations on two new sciences" published in the Netherlands in 1638. This work, in addition to laying the foundations of classical mechanics, was responsible for revolutionary observations in the field of astronomy related to the development and use of the telescope, changes in the fields of geometrical optics (lenses, reflection and refraction of light), thermology (invention of thermometer), hydrostatic, physical optics nature of light (Drake, 1978; Cohen, 1980).

Moreover, his works and his systematics paved the way for others, such as Isaac Newton, especially in mechanics and in his universal gravitation, describing planetary movements. Further on his system of reference to explain relative motion influenced Albert Einstein's theory of relativity.

In the text on the two new sciences, the concept of uniformly accelerated movement, motive of controversy at the time, is proposed and debated between Simplicio, who was sympathetic to Aristotle, and Sagredo,

who was a contemporaneous wise man, and Salviati that was like a Galileo's spokesperson. Unlike the current textbooks, where the various movements are described by some mathematical formulas, at that work the definition of uniformly accelerated motion is reached only after a long discussion of the movements generally observed (Drake, 1980; Favaro, 1938; Cohen, 1980). Galileo was concerned with defining each type of movement that could be expressed mathematically. The uniform motion, in which a body travels equal distances at equal intervals of time, is mathematically described by a space traveled (S) proportional to the time elapsed (t), as: $S = vt$, where (v) is the velocity of the body. In the details of the discovery of this law, one appreciates the valuation of the experiment for the verification of the senses and the technique in comments on the "repetition of an experiment in more than a hundred times".

In fact, it is quite widespread in the textbooks that Galileo arrived at the law of free fall starting from the experiment of the inclined plane. In free fall a body travels in equal times distances proportional to the odd numbers, that is, the distance traveled is proportional to the square of time. For example, a sphere travels a distance 4 times greater in 2 seconds than in 1 second or a distance 9 times greater in 3 seconds. Thus it was possible to show that the distance traveled starting from rest increased with the time square, that is, $S \sim t^2$. On the other hand, it is important to emphasize that this was a fundamental step for the formulation of the first and second laws of the movement of Isaac Newton (Cohen, 1980). In the same arrangement, different spheres were used to show that acceleration is independent of weight as long as the effects of air resistance can be neglected. By increasing the inclination of the plane, the sphere would descend faster and faster approaching the acceleration of free fall $g = 9.8\text{m/s}^2$ (Gilbert and Zylberstajn, 1985). It has also been found that the spheres acquire the same amount of velocity in each successive time interval, ie, ($v \sim t^2$) (Drake, 1978; Gilbert and Zylberstajn, 1985).

2. The Inclined Plan Experiment in School Education

This work, focus the history of science to motivate students about the importance of mathematical language for the understanding of a physical phenomenon, as well as its construction and understanding with the use of new technologies. More specifically, here is used the LEGO Mindstorms NXT Kit, in learning the concepts of movements briefly presented earlier. In this sense, the famous Galileo Inclined Plane experiment is "recreated" using several LEGO pieces and light sensors and the NXT-G software for data acquisition as shown in Fig. 1.

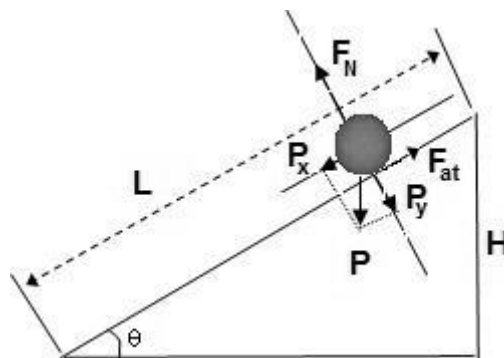

Figure 1. Forces and its components acting over a sphere with M mass and R radius in a inclined plane with height H and length L .

While using a more sophisticated system, students will come across some difficulties encountered by Galileo regarding the accuracy of measurements before getting the relationship between space and time. In addition, other factors that interfere with movement such as friction, spin, slip and air resistance will form part of the mathematical model that culminates in the free fall motion. Thus, a new pedagogical approach is proposed to be used by high school students in the study of the concepts of speed, acceleration and gravitational acceleration, measures of time, conservation of energy, among others, beyond the traditional and boring routine of the textbook and the resolution of mathematical exercises.

In the schools, after contextualizing the historical aspects, evolution of the concepts about the movement and its physical and mathematical definition, students are stimulated in the laboratory to confront the concepts previously discussed with the possibilities of movement of a sphere in the inclined plane. At first, the experiment and the measurements are carried out following a script, that is, an experimental guide in the structured laboratory mode. In the next moment, when the student would be more familiar with the laboratory, they are encouraged to discuss among themselves and propose their measures and experiences to respond to new proposed problems. In both cases, part of the measurements is done manually and another is got automatically via NXT prototype for data acquisition, such as time, with an accuracy of milliseconds. It is intended that the integration between theory and practice in science teaching be stimulated by use of new technologies.

Recent works have drawn attention to the fact that the students are showing a lack of interest in learning the basic knowledge in the area of Physics, since this is addressed in lectures focused on the passive transmission of concepts, usually restricted to the resolution of mathematical problems and exercises of memorization (Kolb, 1984; Danhoni and Arguello, 1986). This trend in directing the teaching of physics to solving problems, which are usually filled with calculations, strongly influenced by the use of textbooks, has been the subject of serious criticism of the publishers and, consequently, the authors of the works. According to Danhoni (1986), this question of how mathematics should be taught and learned in the context of physics needs to be better analyzed. For Albanese et al, (1997) solving a problem in Physics should not be a mere exercise of application of formulas, but above all an understanding of Nature and the physical principles involved. On the other hand, it is understood that the act of teaching is a complex activity for each teacher, and surrounded by risks of failure for each of his students or for the dynamic set of a classroom. The teaching / learning process is quite complex and admitting that knowledge is a personal achievement of the learner, it is understandable that any methodological proposal, however good, not guarantee learning. It should be assisted by the competence of the teacher and the student's awareness and willingness to learn. In this way, the fundamental focus in this work is to arouse the student interest, and the teacher has the difficult task of offering the student favorable conditions for learning and building knowledge, its history, its epistemic bases, and its contingencies.

Starting with the idea of stimulating the student in a non-traditional way, it is proposed in here that the student will verify if it is possible to show experimentally the theory of the fall of the bodies. With the realization of the inclined plane experiment in science or mathematics classes using robotics, it is hoped to create an environment favorable to the learning of concepts and obtain the relations discussed above,

besides increasing students' interest in science in general.

3. Application of Newton's Laws in the Bearing of a Ball without Sliding

As noted by Galileo in his work, the dissipative forces of motion of a sphere rolling in a plane, in an ideal situation, could be disregarded. The idea of replacing a free fall motion with the scrolling movement along a ramp could "facilitates" its study since it decreases the acceleration, increasing the time spent to travel the same distance as in the vertical movement. It is noteworthy that in Galileo's time the mathematical analysis of the scrolling would be a strong complication. Within this context, it was disregarded by him that bodies rolling flat below accelerate less than bodies sliding down in the absence of friction.

In this bearing the gravitational force leads to an increase in the speed of rotation of the sphere resulting in acceleration a_{cm} of the center of mass. Consider a sphere of mass M and radius R as shown in Fig. 1. In the absence of sliding, a static frictional force F_{at} between the sphere and the inclined plane leads to a smooth scroll. In addition, the acceleration a_{cm} is related to an angular acceleration α given by:

$$a_{cm} = \alpha R \quad (1)$$

At Fig. 1 the other forces involved are weight (P) that can be decomposed in tangent (P_x) and normal (P_y) to the inclined plane and the reaction force normal to the plane as (FN).

From Newton's 2nd law in linear form $F = Ma$ along the x-axis and for the sphere rolling smoothly downwards we have:

$$Mg \sin \theta - F_{at} = Ma_{cm}$$

which leads to linear acceleration of the center of mass:

$$a_{cm} = g \sin \theta - \frac{F_{at}}{M} \quad (2)$$

where the acceleration of descent depends on the gravitational acceleration (g), the slope of the ramp (θ) and the friction force, which is also unknown.

However, it can saw the 2nd law of Newton in the angular form ($\tau = I\alpha$) to describe the rotation around a horizontal axis passing through the center of mass ($\tau = r \perp F$) leading to the following relation:

$$\tau = RF_{at} = I_{cm}\alpha \quad (3)$$

where I_{cm} is the moment of inertia of the body in relation to the center of mass. Solving Eqs. (2) and (3) for the acceleration of the center of mass has:

$$a_{cm} = (g \sin \theta) / (1 + I_{cm} / MR^2)$$

In the case of a uniform spherical shell of radius R , ($I_{cm} = \frac{2}{3}MR^2$) that results:

$$a_{cm} = (3/5)g\sin\theta \tag{4}$$

Note that in the case of a maximum slope, that is, $\theta = 90^\circ$ to a_{cm} is not the expected value in the free fall.

4. Application of Newton's Laws in the Bearing of a Ball without Sliding

From the point of view of the conservation of mechanical energy, during the descent, part of the gravitational potential energy (K) of the sphere is converted into kinetic energy of translation (KT) and part of the energy of rotation (KR), both around the its center of mass. Whereas for an object that simply slides, all this energy is converted into its linear translation motion. Therefore, the mechanical energy at any position of the ramp is given by expression:

$$K = \frac{Mv^2}{2} + \frac{I_{cm}w^2}{2} \tag{5}$$

where v is the velocity of its center of mass and w its angular velocity. Both velocities are related through the equation $v = wR$, which applied in Eq. (5) yields:

$$K = \frac{Mv^2}{2} + \frac{1}{2} \left[\left(\frac{2MR^2}{3} \right) \left(\frac{v}{R} \right)^2 \right] = \frac{5}{6} Mv^2 \tag{6}$$

From the specific energies, it is possible to estimate the percentage of the translational energy f_T in relation to the total kinetic energy K by calculating the ratio between the two, that is:

$$f_T = \frac{K_T}{K} = \frac{\frac{1}{2}Mv^2}{\frac{5}{6}Mv^2} \tag{7}$$

The parameter f_T shows that only 60% of the kinetic energy of the system is related to the translation of the center of mass of the sphere. Although this calculation is correct, in practice it may need adjustments. In fact, in the leaning plane of the Lego Kit used in the experimental setup, the sphere descends by a rail that touches the sphere at two points rather than a single point, as developed above. The adjustment is made considering the effective radius (h) or radius of rotation, as in the geometry of Fig. 2, where $h = \sqrt{R^2 - \left(\frac{l}{2}\right)^2}$.

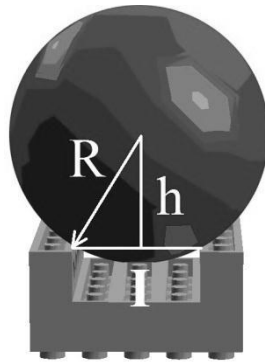

Figure 2 . Geometry of the sphere in contact with the ramp

Considering the effective radius h in Eq. 6 that combines the energies involved:

$$K = \frac{Mv^2}{2} + \frac{1}{3}MR^2\left(\frac{v}{h}\right)^2 = Mv^2\left(\frac{1}{2} + \frac{1}{3}\frac{R^2}{h^2}\right) \tag{8}$$

Making the correction the new parameter f_T is given by:

$$f_T = \frac{K_T}{K} = \frac{\frac{1}{2}Mv^2}{Mv^2\left(\frac{1}{2} + \frac{1}{3}\frac{R^2}{h^2}\right)} = \frac{1}{1 + \frac{2}{3}\frac{R^2}{h^2}} \tag{9}$$

Therefore, for the sphere used in this work with radius $R = 26mm$ and channel width $l = 23mm$ the parameter is corrected for $f_T = 0.55$.

Still considering only the gravitational force, which is a conservative force (the other forces are normal to the movement and therefore do not performs work) we can apply the principle of conservation of mechanical energy to the sphere-Earth system:

$$K_f + U_f = K_i + U_i \tag{10}$$

where the indexes f and i refer to the final values (at the base of the ramp) and initial values (at the top of the ramp). For the resting sphere at the top of the ramp, we initially have a kinetic energy $U_i = 0$ and potential $U_i = MgH$ while at the base of the ramp the energies are $K_f = 1/2Mv^2$ and $U_f = 0$, respectively.

On the other hand, when the sphere begins at the top of the ramp, a fraction of the gravitational potential energy U given by $f_T MgH$ is associated with the work done on the path. This fact is expressed by the expression $U = -W$.

$$\begin{aligned}
 W &= P_x L \\
 f_T M g H &= -M a L \\
 f_T g \frac{H}{L} &= a_{cm} \\
 a_{cm} &= f_T g \sin \theta
 \end{aligned} \tag{11}$$

As expected, the two approaches reveal the same result through Eqs. (4) and (11) just by considering the radius of spin. On the other way, both equations do not lead to the gravitational acceleration value for the maximum inclination of the plane.

In this work we compare the results theoretically estimated by Eqs. (4) or (11) with the acceleration obtained directly from the experimental results of space x time using a simple experimental set up employing a LEGO system presented as follow.

5. The Mindstorms NXT

In 1998, the MINDSTORMS RCX (Robotic Command Explorer) line was commercially launched as result of a partnership between the Media Lab Massachusetts Institute of Technology (MIT) and the LEGO Group. After this, in 2006 LEGO launched the MINDSTORMS NXT version, more advanced, with more resources and processing capacity, which is the one used in this work (Astolfo, Ferrari and Ferrari, 2007).

LEGO MINDSTORMS NXT kit consists of a set of LEGO traditional parts, a processor (NXT Intelligent Brick) which is the processing unit, as well as motors and sensors (Gasperi, Hurbain and Hurbain, 2007). With the NXT it is possible to build a multitude of automata models. At first contact the NXT looks like a simple toy, however, contrary to this common initial sense, it is much more than that. What happens is that if children are using NXT, adults say they are joking while an adult can seamlessly do research with NXT. And really, its processing capacity and assembly possibilities, allow the construction of prototypes aimed at the scientific environment.

Just as an example, researchers have already sent NXT robots to the space frontier to conduct experiments on high altitudes. Because it is small and easy to use, its versatility is enough to put it on a plateau where scientists can effectively perform their experiments.

NXT kits include pieces (beams, pins, bricks, etc.) that are lightweight and sturdy and provide great versatility in terms of assembly, despite their particular geometry. On the other hand, NXT motors and sensors allow the assembly of automata prototypes that move and react with the environment, following predetermined commands. The kits contain three motors that have been designed properly to allow movement by either wheels or treadmills. These can even be used to create claws, hands, or any other prototypes that need movement. In general, it is common to find robots that use a pair of engines to get around and have the third engine for another more specific task.

LEGO manufactures various types of sensors (Fig. 3) which, depending on the version, can be:

- **Ultrasonic:** Measures the distance to an object or obstacle;
- **Touch:** detects when the sensor button has been pressed, released or bumped;
- **Light:** Measures the intensity of light that falls on the sensor's receiver, differentiating from white

(maximum light) to black (absence of light), and gray (intermediate) tones. It has a light source that is used to measure reflected light;

- **Color:** identifies the color of the objects, and can act as if it were a light sensor;
- **Sound:** Measures the sound level around the sensor.

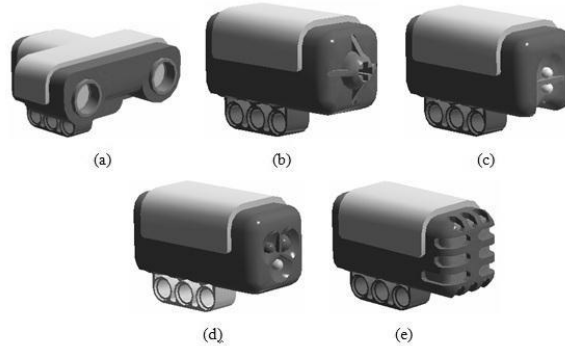

Figure 3 . NEXUS Sensors: a) ultrasonic, b) touch, c) light, d) color, e) sound

In addition to these sensors, the NEXUS motor (Fig. 4) has an internal encoder that allows measuring the number of turns (or angles) executed.

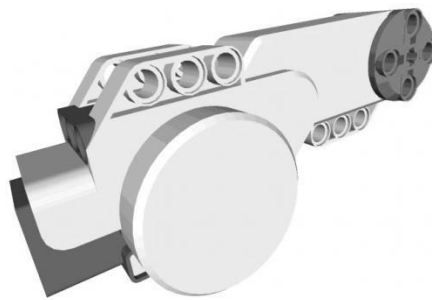

Figure 4 . NEXUS Motor

Other companies manufacture different types of sensors, such as HiTechnic and MindSensors that provide temperature sensors, RFID, accelerometers, gyroscopes, among others, which are sold separately.

The NEXUS brick (Fig. 5) is actually a small computer programmable in order to perform the desired tasks. Because it is compact it has only one set of buttons and a monochrome display, plus four sensor inputs, three motor inputs and one USB port.

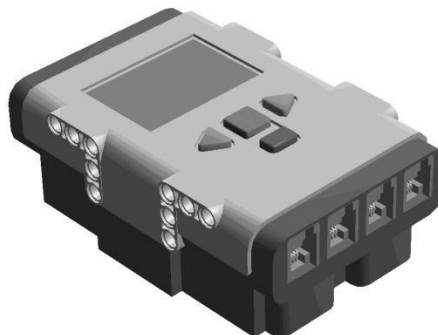

Figure 5 . NEXUS Brick

When a program is created on the computer it is loaded into the brick by a USB cable or a Bluetooth

connection. Once the program is started, the sensors "pick up" the environment and the motors are activated to perform the scheduled tasks (Kelly, 2007).

The NXT native programming is called NXT-G, which was developed for the easy understanding of children, thus being a graphical language where commands are inserted in the programming line (which is a track) by means of easily configurable blocks (Fig. 6).

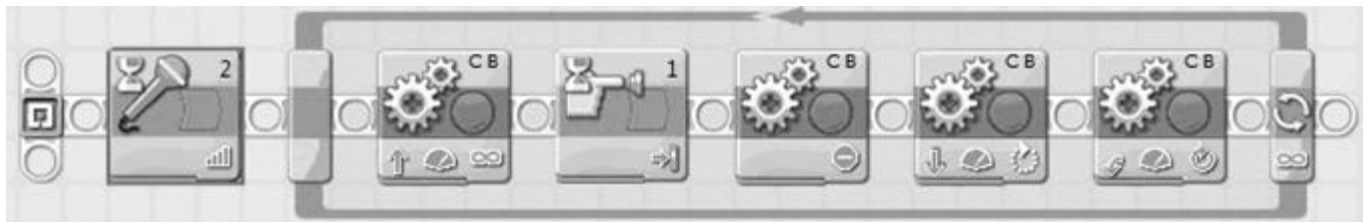

Figure 6 . Programming example NXT-G

6. The NXT Inclined Plane

To construct the inclined plane proposed by Galileo using the NXT kit, several bricks and beams were used to represent the channel where the ball rolls, four light sensors, arranged along the channel and a motor that releases the claw that holds the ball at the beginning of the experiment, at the top of the ramp (Fig. 7).

The prototype allows the ramp to be positioned at angles of 30, 45, 60 and 90 degrees in relation to the support plane.

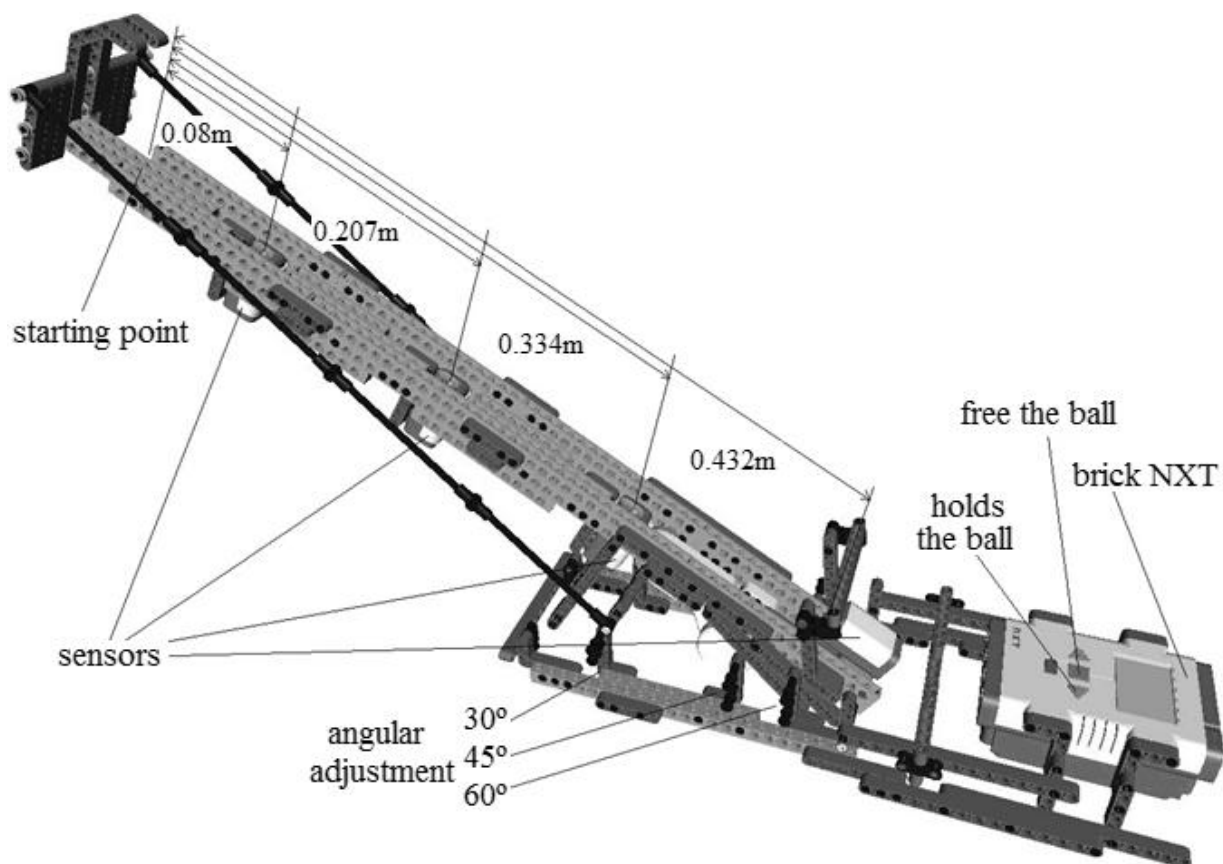

Figure 7 . NXT inclined plane prototype

The distances that the sphere travels from the starting point, at the top of the channel, until the first sensor, the second, third sensor and the last sensor are respectively 0.08, 0.207, 0.334 and 0.432 m. Students may be encouraged to take these distances with a ruler or other measuring instrument and compare their results. According to the programming developed for the prototype, the gray triangular button (right) serves to clamp the ball with the claw at the top of the chute and the orange square button is used to release the ball and start timing. The light sensors detect when the sphere is on them and record the exact time of their passage (in milliseconds) from the starting point. For each angle, clips are used, which fix the channel in the positions of 30, 45 and 60 degrees. The experiment can still be performed by positioning the channel perpendicular to the plane on which it is supported (90°), simulating a free fall.

7. Programming

It is important to say that the light sensors are very sensitive to ambient light, that is, the light from a window or from the room itself that directly affects the channel affects the reading of the sensors. This also happens when the angle of the experiment is changed.

To solve this problem, it is necessary to calibrate the sensors according to the light under which the prototype is inserted. For this purpose, a calibration program has been developed that must be executed each time the prototype is moved, or the angulation is changed. This program is very simple and works with the initialization of all the sensors, when nothing should be placed in front of any of the sensors, that is, it is necessary that the ambient light affects them without any obstacle. This should last 3 seconds. From there, messages are displayed on the brick's display, indicating the moment where the ball should be placed exactly on the sensors, starting from the sensor of the highest part of the channel to the one of the lowest part, successively, respecting the time of 3 seconds on each of them. Once this process is completed, the prototype is perfectly calibrated so that the ambient light will no longer be an interfering factor until the prototype is moved and the calibration process will need to be performed again.

The main programming is also simple. It waits until the ball is positioned at the top of the gutter and the gray triangular button (right) of the brick is used to drive the motor which, by means of a pair of stems, moves the claw firmly holding the ball. Thus, by pressing the orange square button of the brick, the ball is released by descending by the channel. Times are counted and displayed on the brick's display. At this point, the user has 15 seconds to remove the ball that is on the sensor from the bottom and note the measured times. And then, the prototype is ready for another collect of time where the process can be repeated.

8. Experimental Mounting and Measures

In the traditional laboratory, the student performs practical activities involving observations and measures, about phenomena previously determined by a teacher. Many of these activities are not relevant from the student's point of view, as both the problem and the procedures for solving it are pre-determined as in a "cookbook." In addition, in the traditional, structured laboratory, assembly operations in the laboratory, data collection activities, and calculations to obtain the expected responses consume much, if not all, of the available time leaving little time for the students to perform the experiment and analyze the results and the

very meaning of the activity performed.

The hollow sphere used in this experiment has a radius $R=26mm$ and an effective radius $h=23mm$ which, through Eq. 11, presents a theoretical correction value given by $f_T = 0.55$.

The experiment consists in measuring the roll time of the ball on the rail relative to some fixed points. Light sensors await the passage of the ball coupled to a digital timer. The experimental data are shown in Tab. 1. In Fig. 8 the position versus time curves ($S \times t$) are shown for the different slopes employed in this study.

Table 1. Experimental Data: position as a function of the time for different inclination angles of the rail

S(m)	$\theta = 30^\circ$	$\theta = 45^\circ$	$\theta = 60^\circ$	$\theta = 90^\circ$
0	0	0	0	0
0.082	322.6	255.2	224.6	211.6
0.210	441.8	350.6	312.2	287.0
0.338	530.0	419.8	377.0	345.2
0.435	559.4	448.2	404.0	363.0

$t(ms)$.

The curves of the mean velocity as a function of time between two consecutive positions are shown in Fig. 9. The results show that the experiment does not satisfy the expected condition of uniformly varied motion. This suggests that different levels of non-conservative forces act during the course of the sphere. It is worth mentioning that the acceleration of the sphere undergoes a great increase in the final part of the ramp. For the final section of the ramp with maximum slope an acceleration of $\sim 9.40m/s^2$ was obtained, relatively close to that of the gravitational acceleration.

In fact, we are not rigorously addressing the measurement errors in our analysis of the experiment because we consider that this is not a usual approach in our high schools. We think that a discussion based on the concept of significant figures of a measure is more appropriate.

Finally, a comparison between the center of mass acceleration obtained through a theoretical estimate (Eqs. (4) and (11) - rectangles) and through the uniformly accelerated equation of motion (triangles) is shown in Fig. An adjustment between the two estimates suggests a correction factor of approximately $f_T=0.63$ considering the entire ramp (circles).

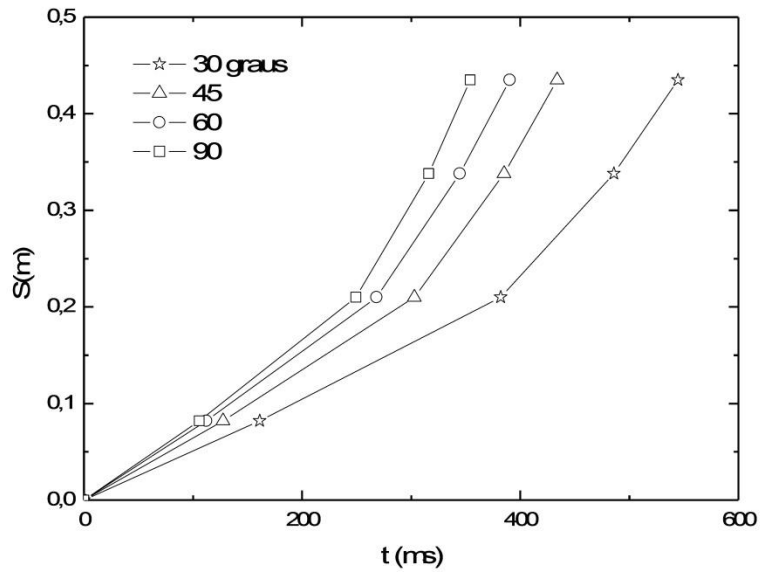

Figure 8 . Ball position as a function of time for different rail slopes.

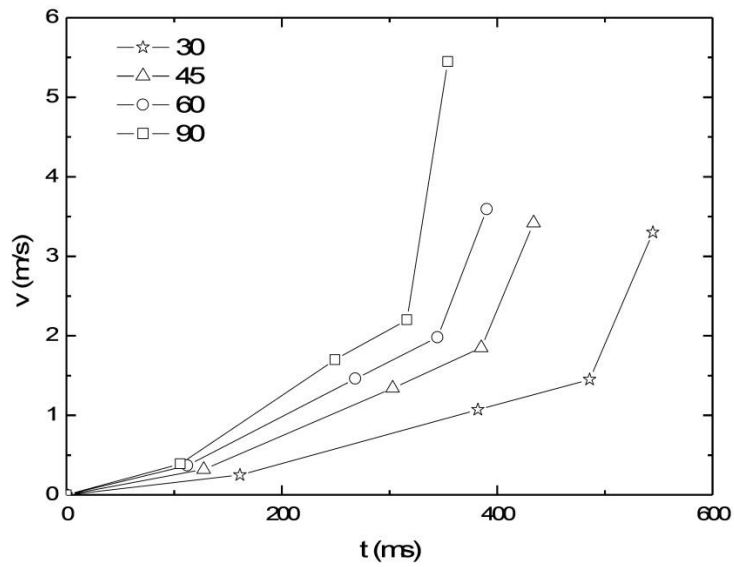

Figure 9 . Average speed as a function of time between two consecutive positions.

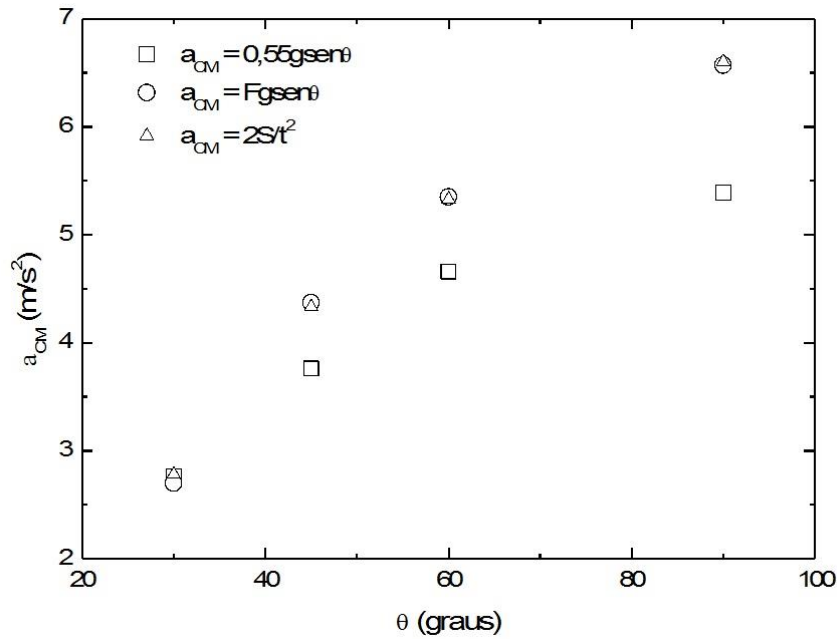

Figure 10 . Acceleration theoretically obtained from energy conservation (rectangles) and obtained experimentally using the ratio $S = \frac{1}{2} a_{cm} t^2$ from the data in Table 1 (triangles). The circles show an adjustment between the two results.

9. Conclusions

In this work an experimental apparatus was presented to perform mechanics experiments by data acquisition with time resolution of the order of mS. One of the expected results would be to obtain the value of the acceleration of gravity around $9.8m/s^2$ for the maximum inclination of the plane. It is believed that some delay or greater interaction between the sphere and the plane in the initial moments of the movement, for the maximum inclination has prevented to obtain the expected value of g. However, in the final section of the plane $g \sim 9.4m/s^2$ was measured.

It should be noted that the rail used in this experiment has a maximum length of 43cm which makes any deviation in the measurements an important source of error. On the other hand, it can be assumed that different magnitudes of the friction force act on the path, and that the slope of the ramp interferes with the dynamics of the ball [11]. In fact, the non-linearity in the $v \times t$ curves shown in Fig. 9 shows that the acceleration increases as the sphere descends the ramp to all slopes. The results also suggest that the situation is more pronounced in the final section of the ramp.

In order to investigate this possibility, the values obtained for the acceleration of the center of mass of the sphere obtained theoretically and experimentally over the whole course were compared. The values of the a_{cm} obtained from the Newtonian mechanics considering the friction force or the bearing and its geometric correction (Eq. 10) are shown in Fig. 10, $a_{cm} = Fg \sin \theta$ ($F=0.55$) (theoretical) and the value obtained for acceleration using the usual equation of uniformly accelerated rectilinear motion ($a_{cm} = 2S/t^2$) (experimental).

Note that an adjustment between the accelerations is obtained for a slightly higher correction factor, that is, $F=0.63$. This increase in F suggests a reduction in the rolling frictional force that implies in the reduction of the rotation of the sphere. As a consequence, it can be assumed that sliding occurs, that is, rolling bearing as shown also in other studies investigating rolling through the inclined plane [12]. The mathematics involved in this analysis is quite simple and can be developed by any high school student.

The great contribution of the work is to point out new methodologies for the teaching of physics, in particular, educational robotics. This certainly, through a practical participation of the students in classes of physics promotes the best understanding of the theory, stimulated by an empirical and constructivist approach of a classic experiment proposed by Galileo in the antiquity.

10. References

- Drake, S., 1978 *Galileo at Work—His Scientific Biography* (Chicago: University of Chicago Press).
- Galileo G. 1914 *Dialogues Concerning Two New Sciences* (New York: Macmillan) (translated from Italian and Latin into English by Henry 320 PHYSICS EDUCATION May 2008 Reconstruction of Galileo Galilei's experiment Crew and Alfonso de Salvio. With an introduction by Antonio Favaro).
- William, A. Wallace, "Galileo's Trial and the Proof of the Earth's Motion," *Catholic Dossier*, 1, no. 2 (July-August 1995): 7.
- Drake, S. Stillman., *Galileo: A Very Short Introduction*. New York: Oxford University Press, 1980.
- Favaro, A., (ed.) *Edizione _azionale delle opere di Galileo*. Firenze: S. A. G. Barbère Editore, 1938, v. 19, p. 21-543.
- Cohen, I.B., *The Newtonian Revolution*. Cambridge University Press, Cambridge, 1980.
- Gilbert, J.K. and Zylberstajn, A. A., A conceptual framework for science education: the case study of force and movement. *European Journal of Science Education*, v. 7, n. 2, 1985.
- Kolb, D.A., *Experiential Learning - Experience as the Source of Learning and Development*. Prentice-Hall, New Jersey, 1984.
- Danhoni, N.M.C. and Arguello, C.A., *Astronomia de régua e compasso: de Kepler a Ptolomeu*, Campinas: Papirus, 1986.
- Albanese, A., Danhoni N. M.C and Vicentini, M., Models in science and in education: a critical review of research on students' ideas about the earth and its place in the universe, *Netherlands, Science & Education* 6: 573-590, 1997.
- Franklin, A., Principle of Inertia in the Middle Ages, *American Journal of Physics*, v. 44, n. 6, 1976, 529-545.
- Grant, E., *Physical Science in the Middle Ages*, John Wiley&Sons, New York, 1971.
- Astolfo, D.; Ferrari, M.; Ferrari, G., *Building Robots With LEGO® MINDSTORMS® NXT*, Elsevier, 2007.
- Gasperi, M.; Hurbain, P.; Hurbain, I., *Extreme NXT - Extending the LEGO® MINDSTORMS® NXT to the Next Level*, APRESS, 2007.
- Kelly, J. F., *LEGO® MINDSTORMS® NXT-G - Programming Guide*, APRESS, 2007.

Copyright Disclaimer

Copyright for this article is retained by the author(s), with first publication rights granted to the journal. This is an open-access article distributed under the terms and conditions of the Creative Commons Attribution license (<http://creativecommons.org/licenses/by/4.0/>).