

Intelligent Systems as Tools for Measuring Residential Energy Consumption

Danilo Silva dos Santos

Graduating of the Bachelor's degree in electrical engineering at University Center FAMETRO, Manaus-AM, Brazil

201 Sapucaia Ave, Manaus - AM, Zip Code:69041260, Brazil

+55 92 99389-5447

danielos.sants@gmail.com

Fabiana Rocha Pinto

Professor and Counselor of the Bachelor's Degree in electrical engineering at University Center

FAMETRO, Manaus-AM, Brazil

fabiana.floresta@gmail.com

Felipe Silva dos Santos

Professor of the Bachelor's Degree in Mechanical Engineering at Foundation Center for Research

Analysis and Technological Innovation FUCAPI, Manaus-AM, Brazil

phelipe.moutinho@gmail.com

Abstract

The implementation of intelligent systems in homes for measuring energy consumption are possibilities that owe their viability to the IoT (Internet of Things and investments in R&D). Becoming fundamental for this change in the way of thinking and using electric power in households, buildings and especially in industry 4.0. The present work demonstrates an experiment focused on a residence for the analysis of energy consumption measurement, with the use of a nano arduino plate, current and voltage sensors, internet connection and use of the MQTT protocol making the integration in the Blynk platform. Obtaining as results voltage approximately 224V, electric current close to 3.89A, 356 points of samples for measurement of consumption and 255 points for preparation of graphs. Minimums for voltage and current 207.75V and 0.62A respectively and maximums 233.22V and 25.31A. A standard deviation of 5.54 for voltage and 3.33 for current. Analyses performed by Blynk, from estimates by mathematical modeling, considered by means of tests and it was observed that the behavior of current and voltage signals are close to the realities of energy distributors.

Keywords: Energy Efficiency; IoT; Arduino; MQTT Protocol; Blynk Platform;

1. Introduction

The potential of renewable energies in Brazil is indisputable, in addition to providing a global financial

return in the sector, public incentive from research and discovery of new sources of energy generation fundamental to the continuous development of the sector. A consequence of this incentive are embedded systems that enable the consumer to improve the energy consumption of the home, avoiding waste and serving as an instrument in reducing the electricity bill.

Camimoto et al (2016) measured and analyzed the total energy efficiency of factors in the BRICS countries (Brazil, Russia, India, China and South Africa), providing information on benchmark countries, a market reference for investors to monitor the performance of their investment. Within this group, Brazil stood out as the country with the highest GDP growth and reduction in the emission of pollutants to the environment, characterizing the advance of energy models through new technologies.

With the technological advance and improvement in the connection of mobile networks, a new concept has been diffused to about projects in homes, buildings and intelligent industries the IoT (Internet of Things). Jara et al (2014) defines the IoT as a technology composed of the so-called intelligent objects, i.e., small physical devices and highly restricted in terms of memory capacity, computing capacity, energy autonomy and communication capacity. In addition to reiterating the objective of the IoT, the integration and unification of the systems that form the communication that surround us. Therefore, the systems will be able to obtain total control and access to other systems, providing communication and ubiquitous computing.

For Palatella et al (2013) the IoT requires software architectures that are able to handle large amounts of information, queries and computing, making use of new paradigms of analysis of collected information, flow, filtering, aggregation and data mining, supported by communication standards. Because existing Internet protocols such as HTTP (Hyper Text Transfer Protocol), TCP (Transport Control Protocol), and IP (Internet Protocol) are not optimized for communication on devices that require low power consumption, this has led to the standardization of instprotocols for the IoT.

Guimarães (2017) portrays the attractive aspects about the IoT that occurs through the monitoring of processes instantly, in addition to access to information across multiple platforms, regardless of location, requiring at least network communication. In the sphere of energy consumption in households, such characteristics can help users to identify the profile of their consumption and do it more effectively.

For the modernization of the electrical system, a new system was developed, the Smarts Grigds (SG), which for Yan et al (2013) are sets of devices, applications and communications, enabling the creation of a widely distributed and automated electrical power supply.

For Brito (2016) GS are intelligent electricity grids that allow the improvement of electric power management working as an integrated network, providing real-time and two-way consumption information between the consumer and the generating units and allowing the readings of electric power consumption to be made remotely.

Given the need for protocols for communication of embedded systems with low energy consumption, the Message Queue Telemetry Transport (MQTT) was developed, where Barros (2015) defines in a protocol for message exchange for IoT. Working on a standard for message exchange publisher/subscriber (Figure 1).

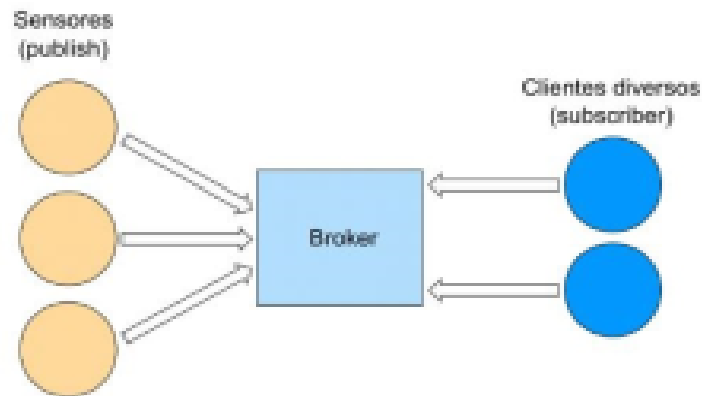

Figure 1. Message exchange manager (broker) of the MQTT protocol.

SOURCE: BARROS, 2015

In this way, when a network device needs information, it subscribes to it, generating a request for another element of the network responsible for managing publications and subscriptions. Within a MQTT network, being this managing element is known as a broker. The publication of information is also done through the broker. Developed by International Business Machines (IBM) in the late 1990s. Originally created to supervise and collect Supervisory Control and Data Acquisition (SCADA) systems, MQTT found its place in the extensive IoT market.

In line with the advance of circuits in real time, which provide information to the consumer in divergent cases, from what occurred to certain electronic generators of energy expenditure, Massimo Banzi, in collaboration with students from the areas of engineering and design developed the arduous embedded system in 2005 (SOUZA, 2013).

The arduino is composed of an Atmel microcontroller, input/output circuits and has the ease of connection to a computer and programmed via IDE (Integrated Development Environment) using a language based on C/C++, without the need for extra equipment besides a USB cable (THOMSEN, 2014).

The Arduino platform (2019) conceptualizes its product as open electronic development and has didactic hardware and software, which facilitate the learning process. Soon the arduous is interested to all who aim at the development of projects for interactive communication with the environment, besides being compatible with IoT technology (Figure 2).



Figure 2. Uno arduino plate.
SOURCE: ARDUINO cc, 2019

Brito (2016) explains that for the development of the arduino IDE, will need a computer, where the necessary programming will be performed for the operation of the project, the sketch is responsible for uploading the information to the Arduino board, either via USB, Bluetooth or Wi-Fi. With this information the developer will perform the interaction of the board with the medium, following the principles of IoT. The following study aims to investigate an intelligent system in arduous connected to the home network showing the user its consumption of electrical energy enabling the same together with this technology use energy in a more rational and sustainable way.

2. Methodology

The prototype for monitoring energy consumption in a household is a system that can be inserted into its energy table, in a non-invasive way and that will collect the necessary information for the analysis through tests of consumption behavior in this house (Figure 3).



Figure 3. Integration of current sensors to the residential distribution board.
SOURCE: Own author, 2019

This device was implemented in a two-phase input. But for testing purposes only. The prototype does the analysis instantly and sends the information through Ethernet Shield, the Blynk platform for analysis through mathematical modeling of the information collected by the current and voltage sensors.

The manufacturing of the device is divided into stages: implementation of the system to the power board, data capture through current and voltage sensors, allocating and enabling the analysis through the arduous. After the reading and execution of this information, the integration between Arduino UNO and Ethernet Shield is done through the internet connection, which enables the sending of these data to the Blynk platform to estimate the consumption in this residence (Figure 4).

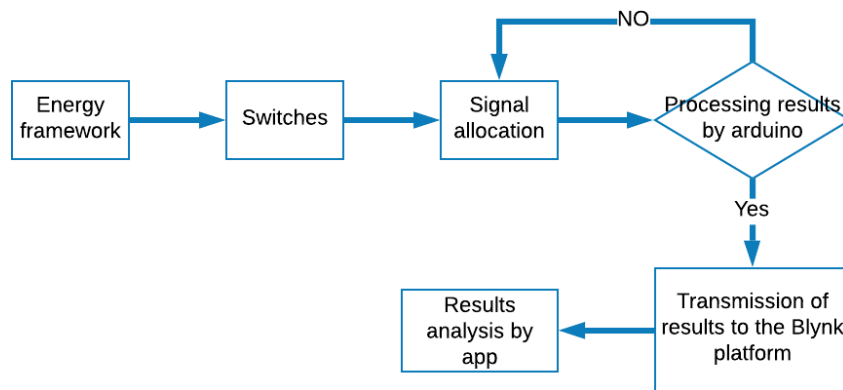

Figure 4. Application flowchart.

SOURCE: Own author, 2019

The prototype will be non-invasive, due to the sensors used and its embedded modules, The system will be integrated to a residence, by means of current and voltage sensors integrated to the energy frame, internet connection (either by wi-fi or internet cable), the Ethernet Shield module, the Blynk platform to estimate the energy consumption of the residence by means of mathematical modeling (Figure 5).

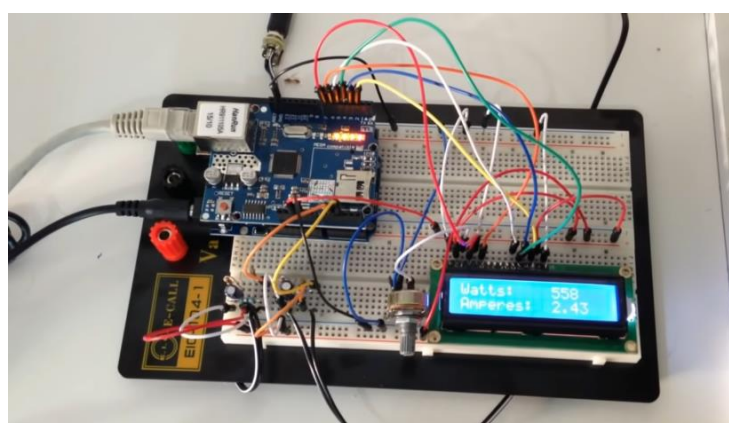

Figure 5. Current meter module in operation.

SOURCE: Own author, 2019

When the data collected from the sensors in the power cabinet is connected to the Internet, it is sent to Blynk. In this platform, all analysis of the sine wave behavior of current and voltage is performed. To

determine if its performance is acceptable, such analyses can prove the efficiency of the results to the consumer to improve the use of their energy.

Before the implementation at the residence, analyses and tests were performed in the laboratory to measure possible mishaps in the actual application, taking into consideration a simplified version of the AC energy meter (Figure 6).

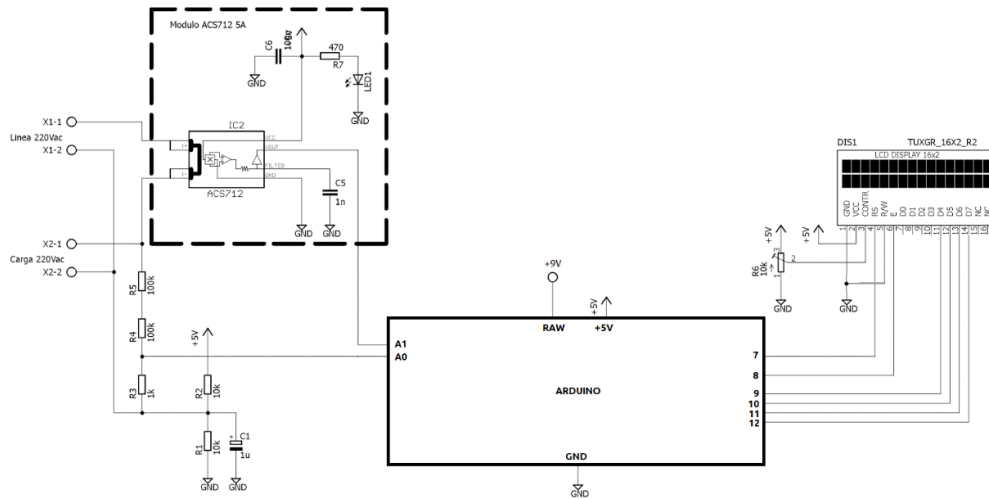

Figure 6. Simplified version of the AC energy meter.

SOURCE: Own author, 2019

It has no operational amplifier stage to perform full wave precision grinding. The method used was based on the assembly of an alternating signal to be measured at 2.5 V continuous (Figure 7).



Figure 7. Experiment without RC filter.

SOURCE: Own author, 2019

A MDS 160 LCD display was connected to the circuit, with a possible visualization of the consumption of an LED lamp. The measurement signal was analyzed without the use of an RC filter and connected to the circuit-breaker and an ASC712 voltage module, with noises that interfere with the measurement analysis. A RC filter was integrated into the circuit and it was found in a new analysis a more proper signal for abstraction of results, proving that the electrical scheme for the proposed energy meter is close to the measurement of the energy suppliers (Figure 8).



Figure 8. Experiment with RC filter.

SOURCE: Own author, 2019

3. Results and discussion

After validation of the effectiveness of the proposed energy meter. There was the implementation of this system based on the electrical circuit schemes, technical specifications and codes for programming in the IDE platform of the arduino according to the Open Energy Monitor (Figure 9).

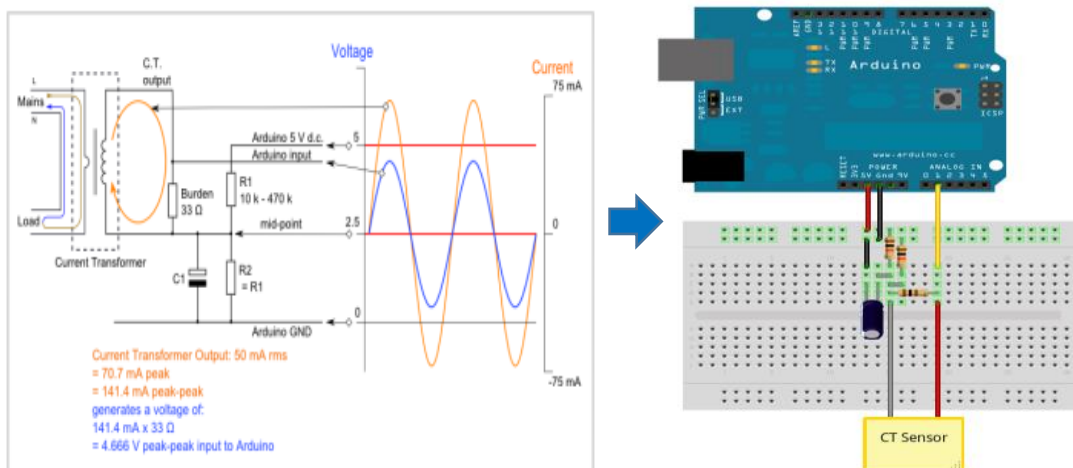

Figure 9. Open Energy Monitor.

SOURCE: openenergymonitor.org, 2019

It was made an analysis for a period of 4 hours of the variation of electric current consumption in the residence to verify the effectiveness of the operation of the project, where from estimates made by Blynk, by means of mathematical modeling considering the tests, it was possible to obtain an estimate of the energy consumption of the residence (Figure 10).

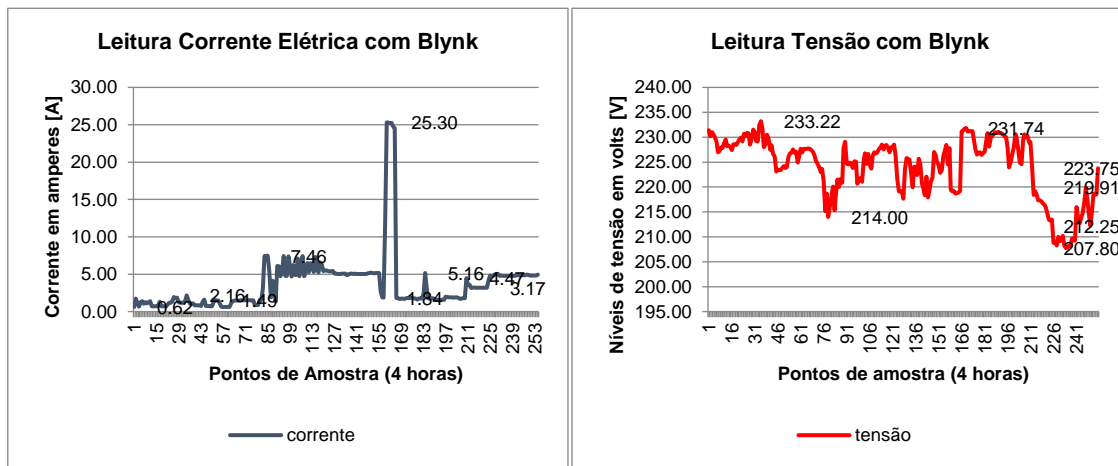

Figure 10. Measurement of residential energy consumption.

SOURCE: Own author, 2019

The voltage considered was approximately 224V, electric current close to 3.89A, 356 points of samples for measuring consumption and 255 points to prepare the graphs. Minimums for voltage and current 207.75V and 0.62A respectively, and maximums 233.22V and 25.31A. A standard deviation of 5.54 for voltage and 3.33 for current.

The Blynk platform provides a simulation of power consumption in real time thanks to the internet connection and the MQTT protocol, not having the same level of accuracy as the utility because they use highly complex software to analyse the consumption of the UC they monitor. But for the purposes of experiments, the platform proved to be useful for presenting data close to reality.

According to Piovesan (2017) circuit simulation has been increasingly accepted as a normal tool in electronics equipment projects. For this reason, simulation is recognized as a practical necessity, becoming an indispensable tool in the training of technicians and engineers, especially in the part related to projects and interpretation of electro-electronic equipment.

The current sensor used in the project can measure the current that is going through a certain phase, through the effect of the magnetic field that goes through its coils and the relationship of these coils already presented as a K factor, collect a sample proportional load in their terminals.

Guimarães (2017) clarifies that the sensors are devices that change their behavior under the action of a physical magnitude, thus, can directly or indirectly provide a signal that indicates this magnitude. In turn, when they operate directly, it converts the energy and another, whose are called transducers.

For Piovesan (2017) the non-invasive current sensor is a circuit for voltage acquisition, collect the energy consumption data in the experiment, these collected data are treated by the microcontroller, thereby obtaining the total consumption of the residence for the invoice comparison with the analysis of the device developed in the project.

The voltage sensor conditions the AC signal obtained in the experiment in analog signals due to the arduino input. Thus, due to the arduino having an operating range of 5 V that cannot be exceeded, there will be damage to the microcontroller. The conditioning is done so that the working range respects the limit of the microcontroller.

The voltage divider serves to raise the reference signal by approximately 2.5 V, eliminating the negative voltage of the sinusoid, just as the electrolytic capacitor is responsible for filtering the signal that will be sent to the AD (Analog / Digital) of the arduino.

Therefore, the experiment demonstrates a real behavior, expected by the literature, relating them to the current and voltage analysis in the residential energy consumption. If implemented to measure the consumption of specific equipment in this residence will become a new technology for the user to estimate with approximation its energy consumption.

4. Conclusions

The conscious use of electric energy avoids its waste, taking into account the exponential growth of consumers of the electric grid. So this work will contribute not only as a scientific study for new developments, but awareness of consumers about their energy consumption and that, from this, can be taken some actions so that besides the reduction of energy consumption, contribute to the environment.

In the tests performed, it was noted the reading of energy consumption in a real way, provides greater knowledge to the customer of their profile of electricity consumption, also disseminating the importance of awareness in energy consumption.

It is worth mentioning that the application of the modules that make up this work is not limited to a single application. The platform with cloud connection is ready to ship several other functionalities and monitor other quantities. It can also be applied for the purpose of power quality sampling or consumption patterns composing a geographically installed data network.

At the end of the development of the work and based on the results obtained, it can be concluded that the installation of the system is a tool that assists the user in the management of electricity consumption. It can be of great value in reducing energy waste. Even if the prototype was developed to measure energy consumption, it can be used in buildings to control various luminaires creating an automatic lighting system.

5. References

- [1] ARDUINO, Ethernet Shield. 2016. Arduino Ethernet Shield Tutorial. Available at: <<https://www.arduino.cc/en/Main/ArduinoEthernetShield>>. Access on: Oct. 10, 2019 (in Portuguese).

- [2] Brito, J.L.G. 2016. System for monitoring private, real-time, non-invasive electrical power consumption using Arduino technology. State University of Londrina (Center for Technology and Urbanism Department of Electrical Engineering), Londrina - PR (in Portuguese).

- BARROS, Marcelo. 2015. MQTT - Protocols for IoT. Available at <<https://www.embarcados.com.br/mqtt-protocolos-para-iot/>>. Accessed on: Oct. 10, 2019 (in Portuguese).

- [3] CAMIOTO, F.C; REBELATTO, D.A.N; ROCHA, R.T. 2016. Analysis of energy efficiency in the BRICS countries: a study involving Data Envelopment Analysis. *Gest. Prod.*, São Carlos, v. 23, n. 1, p. 192-203, 2016 (in Portuguese).
- [4] GUIMARÃES, G.S.B. 2017. Internet of Things: Development of a Power Meter for Residential Electrical Equipment with Internet Connection. Federal University of Minas Gerais (Undergraduate Course in Electrical Engineering), Belo Horizonte - MG (in Portuguese).
- [5] JARA, Antonio; LADID, Latif; SKARMETA, Antonio. The Internet of Things through IPv6: An Analysis of Challenges, Solutions and Opportunities. *Journal of Wireless Mobile Networks, Ubiquitous Computing, and Dependable Applications*, 2014. Available at: <<http://iot6.eu/sites/default/files/imageblock/ipv6-iot.pdf>>. Accessed Oct. 10, 2019.
- [6] SOUZA, Fábio. 2013. *Arduíno - First Steps*. Available at: <http://www.embarcados.com.br/arduino>>. Accessed Oct. 10, 2019 (in Portuguese).
- [7] OPENERGYMONITOR. 2019. *Interface With Arduino*. Available at: <<https://learn.openenergymonitor.org/eletricity-monitoring/ct-sensors/interface-with-arduino>>. Accessed Oct. 11, 2019.
- [8] PALATELLA, M. R.; ACCETTURA, N.; VILAJOSANA, X.; WATTEYNE, T.; GRIECO, L. A.; BOGGIA, G.; DOHLER, M. 2013. "Standardized protocol stack for the Internet of (important) Things", *IEEE Communications Surveys & Tutorials*, 15 (3), 1389-1406.
- [9] THOMSEN, Adilson. 2015. How to make an electric energy meter with arduous. *Filipeflog Blog*. Available at: <<http://blog.filipeflog.com/arduino/medidor-deenergia-eletrica-com-arduino.html>>. Accessed on Oct. 11, 2019 (in Portuguese).
- [10] YAN, Y.; QIAN, Y.; SHARIF, H.; TIPPER, D. 2013. A survey on smart grid communication infrastructures: Motivations, requirements and challenges. *IEEE Communications Surveys & Tutorials*, 15 (1), 15-22.

Copyright Disclaimer

Copyright for this article is retained by the author(s), with first publication rights granted to the journal. This is an open-access article distributed under the terms and conditions of the Creative Commons Attribution License (<http://creativecommons.org/licenses/by/4.0/>).