

Water and Energy Savings in Microirrigation Systems Design Using Optimization Models

João Carlos Cury Saad¹ ; Evanize Rodrigues Castro²

1PhD, Full professor, São Paulo State University (UNESP), School of Agronomical Sciences, Campus Botucatu, Av. Universitária, 3780, Botucatu, SP, 18610-034, Brazil, joao.saad@unesp.br ORCID: 0000-0002-8314-7758. Corresponding author

2Mathematician, MSc, São Paulo State University (UNESP), School of Agronomical Sciences, Campus of Botucatu, evanizecastro@gmail.com

Abstract

The main disadvantage of trickle irrigation systems is its comparatively high initial cost, which depends on the layout, design, and management of its hydraulic network. Designing the sub-main and lateral lines aiming the emitter uniformity maximization can reduce the microirrigation system costs. This research aimed to compare linear and nonlinear programming models and maximization versus minimization criteria to optimize the crop net benefit, considering the water and energy savings. Two versions of LP and NLP models were developed: the first minimized the equivalent annual cost of the irrigation system considering the pipeline cost and the energy cost; the second maximized the yearly increment in the net benefit (Bn) of the irrigated crop. In both cases, uncertainty about the crop price was considered. The models were applied in a 40 ha citrus orchard in São Paulo State, Brazil. The highest net benefit was found using the NLP model with the maximization criterion. The worst result was obtained with the LP model and the minimization of the total annual cost. The layout and management previously established by the designer are subjective and rarely results in the best solution, although the linear programming model always gets the global optimum. The NLP models get local optimal, but they defined the layout, design, and management of the systems, with more chance to obtain a higher net benefit. The NLP model for maximization showed to be an adequate option for designing microsprinkler irrigation systems, defining the hydraulic network and the operational conditions that maximize Bn and WUE, with the lowest water consumption and lowest energy cost.

Keywords: Linear programming; nonlinear programming; trickle irrigation; maximization; citrus; profit.

1. INTRODUCTION

Trickle irrigation is a convenient and efficient method of supplying water, in high frequency, and low volume, to the root zone of crops and trees [1]. It stands out for its agronomic and environmental advantages, such as the possibility of automation, irrigation systems durability, fertigation adequacy, and improvement of the water resources management [2];[3].

As a permanent irrigation system, the hydraulic network design greatly influences the initial equipment cost and also the energy consumption. Thus, optimization of the system design is key to maximizing profitability and emission uniformity.

Microirrigation systems are recommended in sloping lands, usually with lateral lines in level, following the row of trees. When the irrigated area has a high slope gradient in the manifold line direction, an option is to use a tapered pipeline. This is done to economize on pipe costs and to keep the pressure head variations within the desired limits. A tapered-manifold system is cheaper, more straightforward, and more durable than a system requiring flow or pressure regulators [4].

Designing the submain and lateral lines aiming the emitter uniformity maximization can reduce the microirrigation system costs by optimizing water use and energy savings [5].

The design criterion adopted in trickle irrigation systems defines the allowable pressure variation in the subunit, and, generally, it is equally divided between lateral and manifold lines. The permissible pressure variation is the difference between the maximum and minimum pressure in the outlets of the line, and the location of these extremes pressure points is required to design the manifold line. In downhill lines, the location of the maximum and the minimum pressure heads are variables and depend on the relationship between the total energy gain by slope and the total head losses due to the pipe friction. There is an analytical solution for single diameter lines, but in the case of tapered lines, the problem becomes more complex and requires complex analytical procedures [6];[7].

Design optimization of trickle irrigation systems using Operational Research has been presented by [8];[9]; [Anonymous, 1994];[11]. [Anonymous, 2002] developed a linear programming (LP) model to design microirrigation systems with tapered, downhill manifold lines, minimizing the equivalent annual cost of the hydraulic network and the annual pumping cost, and maximizing the emission uniformity.

A nonlinear programming (NLP) model was developed for the design and management of a trickle irrigation system and applied it in a flat area [13]. The model was extended the application of the nonlinear model to sloping areas [Anonymous, 1996]. Because both models work with the diameter as a continuous variable, the hydraulic network is designed with diameters that are usually not available as nominal diameters.

The enumeration approach was used by [15] in a nonlinear model for the optimum design and operation of drip irrigation systems. Still, it was applied only on flat terrain. [16] developed a method for designing microirrigation subunits using the lateral flow rate equation, finite element method, and the golden section search. The procedure allows designing the manifold line with different lengths in the uphill and downhill sections to compensate for the slope gradient. This is the right solution for a low gradient slope. In situations with high slope, however, the entire manifold line must be downhill to assure the desired emission uniformity in the subunit.

This research aimed to compare linear and nonlinear programming models and maximization versus minimization criteria to optimize the crop net benefit, considering the water and energy savings

2. MODELS DEVELOPMENT

In this research, four optimization models were developed: a) NLP-MAX – a nonlinear programming model to maximization of the annual increase in the crop net benefit due to irrigation adoption; b) NLP-MIN - a nonlinear programming model to the minimization of the yearly cost of the irrigation system considering the pipeline cost and the energy cost; c) LP-MAX – a linear programming model to maximization; and d) LP-MIN - a linear programming model to minimization.

The models were used in a 40-ha citrus orchard in São Paulo State, Brazil, to compare linear and nonlinear models and maximization versus minimization criteria.

The assumptions in the models were as follows:

- (1) the area must be rectangular;
- (2) the pump and control stations are placed at the middle of one edge of the field (in the x-direction);
- (3) the lateral lines are polyethylene and are in level. The others are polyvinyl chloride (PVC);
- (4) the uncertainty in crop prices is considered.

A trickle irrigation system is usually composed of subunits, that in this paper, consist of emitters (or microsprinklers), pipes (laterals, manifold, and auxiliary), and accessories such as valves (Figure 1).

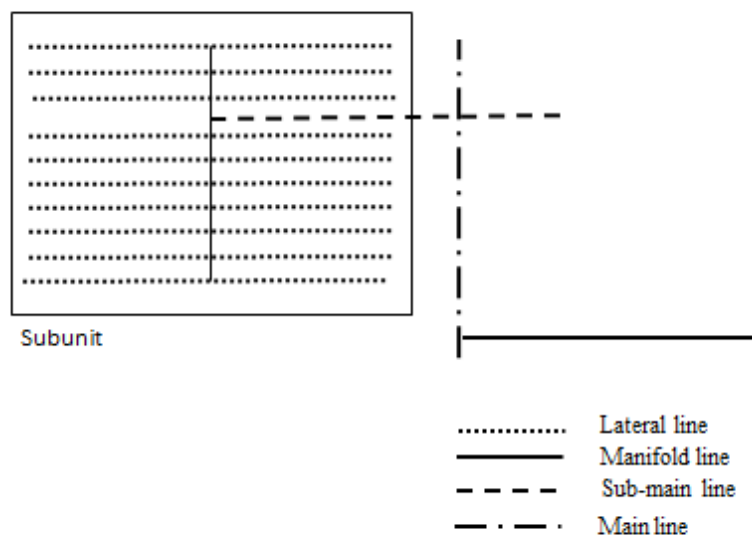

Fig 1. Subunit configuration, submain, and main lines adopted by the optimization model.

2.1. Nonlinear model – Maximization (NLP-MAX)

2.1.1. Objective function

The objective function to be maximized is the annual increase in the net benefit when the irrigation is adopted and is given by:

$$B_n = B_g - C_{ip} - C_{prod} \tag{1}$$

where B_n = annual increase in the crop net benefit due to irrigation adoption, in US\$/ha.yr; B_g = annual increase in the crop gross benefit due to irrigation adoption, in US\$/ha.yr; C_{ip} = annual cost with

investment and pumping (cost of irrigation system) in US\$/ha.yr; C_{prod} = annual production cost without irrigation, in US\$/ha.yr.

The increase in the crop gross benefit is given by:

$$B_g = P \Delta Y \tag{2}$$

$$\Delta Y = Y - Y_r \tag{3}$$

in which P = product price in US\$/kg; ΔY = increase in the actual yield when irrigation is adopted, in kg/ha.yr; Y = crop yield with irrigation, in kg/ha.yr; Y_r = yield in rainfed condition, in kg/ha.yr.

The yield increases due to irrigation (Y), when any other required resource is at the optimum level, was estimated by:

$$Y = AW^2 + BW + C \tag{4}$$

where W = volume of water applied per tree, per year; A, B and C are regression coefficients.

The volume of water applied per plant (or tree) per season (W), in m^3 , is given by:

$$W = (3600N_m q_w I_d I_h E_a) / I_f \tag{5}$$

where N_m = number of emitters per emission point; q_w = average emitter discharge in m^3/s ; I_d = number of irrigation hours per set of subunits working simultaneously, during an irrigation interval; I_h = number of irrigation days during the year; E_a = application efficiency; I_f = number of days in the irrigation interval (irrigation frequency).

The annual production cost without irrigation is calculated by:

$$C_{prod} = C_{pb} \cdot \Delta Y \tag{6}$$

where C_{pb} is production cost in US\$/kg.

The cost with investment and energy (C_{ip}) is:

$$C_{ip} = \{[(C_{mi}TM + C_{pe}TLL + NSU LM C_{pvm} + C_{pva} TAL + C_{pvs} TSL + C_{pvn} TNL + CV + CCP + CF + CP)CRF + CPP + CW]1000\} / At \tag{7}$$

where C_{mi} =microsprinkler cost, in US\$/unit; TM = microsprinklers total number; C_{pe} =cost (US\$/m) of polyethylene pipe expressed as a function of the diameter (m); TLL = lateral line total length in m; NSU = number of subunits; LM = manifold line length in m; C_{pvm} = cost (US\$/m) of PVC pipe

expressed as a function of the manifold line diameter (m); C_{pva} = cost (US\$/m) of PVC pipe expressed as a function of the auxiliary line diameter (m); TAL = auxiliary line total length in m; C_{pvs} = cost (US\$/m) of PVC pipe expressed as a function of the submain line diameter (m); TSL = total length of submain line in m; C_{pvn} = cost (US\$/m) of PVC pipe expressed as a function of the main line diameter (m); TNL = total length of main line in m; CV = cost (US\$) of valves; CCP = cost (US\$) of control panel; CF = cost (US\$) of filter system; CP = cost (US\$) of the pump station; CRF = capital recovery factor; CPP = annual pumping cost (US\$/yr); CW = water cost (US\$/yr), and At = total area, m².

The pipe costs expressed as a function of line diameter were obtained by regression and are given by:

$$C_{pe} = C_1 (DL) - C_2 \quad (8)$$

$$C_{pvm} = C_3 (DM)^{C_4} \quad (9)$$

$$C_{pva} = C_5 (DA)^{C_6} \quad (10)$$

$$C_{pvs} = C_7 (DS)^{C_8} \quad (11)$$

$$C_{pvn} = C_9 (DN)^{C_{10}} \quad (12)$$

where DL is the lateral line diameter, in m; DM is the manifold line diameter, in m; DA is the auxiliary line diameter, in m; DS submain line diameter, in m; DN is the main line diameter, in m; $C_1, C_2, C_3, C_4, C_5, C_6, C_7, C_8, C_9$ and C_{10} are coefficients.

The amount of each item in a trickle irrigation system can be obtained with the following equations:

$$LL = (NML - 0.5)S_M \quad (13)$$

$$LM = LMU + LMD \quad (14)$$

$$LMU = (NLLU - 0.5)S_L \quad (15)$$

$$LMD = (NLLD - 0.5)S_L \quad (16)$$

$$LMD = JP L_M \quad (17)$$

$$LA = NML S_M \quad (18)$$

$$LS = L_Y - (NLLU S_L) \quad (19)$$

$$LSUX = 2NML S_M \quad (20)$$

$$LSUY = NLL S_L \quad (21)$$

$$TM = (A N_m) / (S_M S_L) \quad (22)$$

$$TLL = NSU NLL S_M [(2NML) - 1] \quad (23)$$

$$TML = (NLL - 1)S_L NSU \quad (24)$$

$$TAL = NSU NML S_M \quad (25)$$

$$TSL = \frac{0.25At}{NML S_M} - \frac{0.25L_X S_L NLLU}{NML S_M} \quad (26)$$

$$TNL = L_X - (4NML S_M) \quad (27)$$

$$NS = TSL/[L_Y - (NLLU S_L)] \tag{28}$$

$$NSL = \frac{NSU LSUY}{2L_Y} \tag{29}$$

where LL = lateral line length, m; NML = number of emission points in a lateral line; LM = manifold line length (uphill + downhill), m; LMU = uphill manifold line length, m; LMD = downhill manifold line length, m; $NLLU$ = number of outlet in the uphill section of the manifold line; $NLLD$ = number of outlets in the downhill section of the manifold line; NLL = number of outlets in the manifold; L_x is the length of field in x-direction, in m; L_y = length of field in the y-direction, in m; JP = manifold position ratio, which gives the same minimum uphill and downhill pressure head along a pair of manifolds.

The cost of valves (CV), in US\$, expressed as a function of the total number of subunits is given by:

$$CV = C_{11} NSU \tag{30}$$

where C_{11} = constant.

The cost (US\$) of control panel expressed as a function of the total number of subunits is given by:

$$CCP = (C_{12}NSU) + C_{13} \tag{31}$$

where C_{12} and C_{13} are constants.

The cost (US\$) of the pump station expressed as a function of the required power is given by:

$$CP = (C_{14}QT HT) + C_{15} \tag{32}$$

where C_{14} and C_{15} are constants; and HT = total head losses plus the total difference in elevation, in m, given by:

$$HT = 0.75HFL + H_{AV} + 0.75HFMU + HFA + HFS + HFN + HCS + 0.5LMU S_Y + LS S_Y C_{pb} Y \tag{33}$$

where HFL = lateral line head loss (m); $HFMU$ = uphill manifold line head loss (m); HFA = auxiliary line head loss (m); HFS = submain line head loss; HFN = main line head loss; HCS = head loss in the control station, m.

The annual cost (US\$/yr) of electric energy expressed as a function of the consumption is given by:

$$CPP = C_{kw} \left(\frac{10.787 Q_{SU} HT I_d I_h NSU}{\eta I_f} \right) \tag{34}$$

where C_{kw} = cost of kWh, in US\$; η = pump and motor efficiency; Q_{SU} = operational subunit discharge (m^3/s).

The annual water cost is:

$$CW = \frac{10,000W P_W}{S_L S_M E_a} \quad (35)$$

where P_W = water cost, in US\$/ m^3 ; S_M = distance between emission points in a lateral line, in m; S_L = distance between lateral lines, in m.

2.1.2 Constraints

The constraints in the present analysis are the hydraulic conditions, the irrigation criteria, the geometric limitations, and the operational characteristics.

In sloping fields, the model solves the design of a trickle irrigation system assuming that the manifold is in the same direction as the slope. The uphill and the downhill section of the manifold line have different lengths, but the same diameter.

The manifold position ration, which gives the same minimum uphill and downhill pressure head in a manifold pair, is calculated by [4]:

$$\frac{SY LM}{HFM} - 0.36 \left(\frac{SY LM}{HFM} \right)^{1.57} = JP^{2.75} - (1 - JP)^{2.75} \quad (36)$$

The Darcy-Weisbach equation is used to determine the pipe head loss. For use with smooth plastic pipes this equation is given by:

$$H_f = 7.89(10^{-4})L \frac{Q^{1.75}}{D^{4.75}} \quad (37)$$

in which H_f = head loss due to pipe friction (m); L = length of pipe (m); Q = flow rate in the pipe (m^3/s); D = inside diameter of the pipe (m).

The head loss in each line is given by:

$$HFL = (8.1267 \cdot 10^{-4} LL QL^{1.75} F_L) / DL^{4.75} \quad (38)$$

$$HFMU = (7.89 \cdot 10^{-4} LMU QMU^{1.75} FMU) / DM^{4.75} \quad (39)$$

$$HFMD = (7.89 \cdot 10^{-4} LMU QMU^{1.75} FMU) / DM^{4.75} \quad (40)$$

$$HFM = HFMU + HFMD \quad (41)$$

$$HFA = (7.89 \cdot 10^{-4} LMU QMU^{1.75} FMU) / DA^{4.75} \quad (42)$$

$$HFS = (7.89 \cdot 10^{-4} LMU QMU^{1.75} FMU) / DS^{4.75} \quad (43)$$

$$HFN = (7.89 \cdot 10^{-4} LMU QMU^{1.75} FMU) / DN^{4.75} \quad (44)$$

where QL = lateral line discharge, m^3/s ; QMU = uphill manifold line discharge, m^3/s ; QMD = downhill manifold line discharge, m^3/s ; QA = auxiliary line discharge, m^3/s ; QS = submain line discharge, m^3/s ; QN = main line discharge, m^3/s ; FL, FMU, FMD, FA, FS and FN are the Christiansen's coefficients for the lateral, uphill manifold, downhill manifold, auxiliary, submain and main line, respectively.

The discharge in each line is given by:

$$QL = NML \text{ NM } QM \tag{45}$$

$$QMU = 2NLLU \text{ QL} \tag{46}$$

$$QMD = 2NLLD \text{ QL} \tag{47}$$

$$QA = 2 \text{ NLL QL} \tag{48}$$

$$QS = NSUS \text{ QSU} \tag{49}$$

$$QN = NSUS \text{ QSU} \tag{50}$$

$$QSU = 2NSUS \text{ NM } QM \text{ NLL NML} \tag{51}$$

$$QSU = 2NLL \text{ NML NM } QM \tag{52}$$

$$QT = 2NSUS \text{ NM } QM \text{ NLL NML} \tag{53}$$

$$2QM \text{ NM NML NLL NSUS} \leq QAV \tag{54}$$

The laterals and manifold lines are designed as a function of the emission uniformity. For design purposes, the allowable head variation in a subunit that will give a reasonable emission uniformity (EU) can be computed by (Keller and Bliesner, 1990):

$$APVS = 2.5 (H_{AV} - H_{MIN}) \tag{55}$$

where $APVS$ = allowable pressure head variation in the subunit (m); H_{AV} = average pressure head in the subunit (emitter working pressure), in m; H_{MIN} = pressure head that will give the minimum emission rate in the subunit (m).

To estimate the emission uniformity for a proposed design, [17] adopted:

$$EU = 100 \left(1 - 1.27 \frac{E_{MV}}{\sqrt{NM}} \right) \frac{q_{MIN}}{QM} \tag{56}$$

in which EU = emission uniformity (expressed as a decimal); E_{MV} = manufacturing variation in emitter expressed as a coefficient of variation; q_{MIN} = minimum emission rate in the subunit (m^3/s).

[4] recommended, as a general design guideline, that the allowable subunit head variation ($APVS$) can be allocated equally between the lateral and manifold head variations. This paper accepted values between 40% and 60%, but the sum must be 100%. Thus:

$$HFL \geq 0.4 \text{ APVS} \tag{57}$$

$$HFL \leq 0.6 \text{ APVS} \tag{58}$$

$$HFMU + (LMU \text{ SY}) \geq 0.4 \text{ APVS} \tag{59}$$

$$HFMU + (LMU SY) \leq 0.6 APVS \tag{60}$$

$$APVS = HFL + HFMU + LMU SY \tag{61}$$

$$A = 2 NML NLL S_M S_L NSU \tag{62}$$

The velocity in the auxiliary, submain and main lines must be between 0.2 and 2m/s, and they are estimated by:

$$VA = 1.27324 \frac{QA}{DA^2} \tag{63}$$

$$VS = 1.27324 \frac{QS}{DS^2} \tag{64}$$

$$VN = 1.27324 \frac{QN}{DN^2} \tag{65}$$

where *VA* is the velocity in the auxiliary line, m/s; *VS* is the velocity in the submain line, m/s, and *VN* is the velocity in the main line, m/s.

The available time to irrigate the total field area is a restriction:

$$\frac{NSU I_h}{NSUS I_{fr}} \leq T_{av} \tag{66}$$

$$\frac{NSU I_h}{NSUS I_{fr}} \geq 18 \tag{67}$$

in which *T_{av}* = number of hours available for irrigation per day.

The nonlinear model defines the layout and the operations conditions of the irrigation system. Some of the outputs are the number of subunits, the number of subunits working simultaneously, uphill and downhill manifold sections length, head losses in all the lines, length of all the lines, allowable head loss in the subunit and others.

The output data from the nonlinear model are used in a Linear Programming model to obtain the final solution with a combination of commercial diameters in all the lines of the hydraulic network, except in the lateral line.

The set of linear equations adopted is based on the model developed by [Anonymous, 2002] only with one modification: in this case, the manifold line has uphill and downhill sections. The constraints are given by:

$$HM_o - HMU_{end} \leq APM \tag{68}$$

$$HM_o - HMD_j \leq APM, \quad j = 1, \dots, J \tag{69}$$

$$HMD_j - HM_o \leq APM, \quad j = 1, \dots, J \tag{70}$$

$$HMD_g - HMD_j \leq APM, \quad \forall j = 1, \dots, J; g = 1, \dots, J; \text{ and } g \neq j \tag{71}$$

$$HMD_j - HMU_{end} \leq APM, \quad j = 1, \dots, J \tag{72}$$

$$HMU_{end} - HMD_j \leq APM, \quad j = 1, \dots, J \tag{73}$$

where HM_o = pressure head at the inlet of the manifold line (m); HMD_j = pressure head at the outlet j of the manifold line (m); HMD_g = pressure head at the outlet g of the manifold line (m); HMU_{end} = pressure in the last outlet of the uphill manifold; and APM = maximum allowable pressure head variation in the manifold line (m).

2.2. Nonlinear model – Minimization (NLP-MIN)

When the objective is to minimize the total cost of the irrigation system, no production function is involved. It is necessary to define the volume water to be applied during the season, and the selection of this value is done according to technical considerations. The volume of applied water that maximizes the production doesn't mean maximum net benefit.

The equations system is almost the same as the maximization problem, except the exclusion of the benefit component in the objective function and production function. The volume of water applied is no more a variable and must be previously selected.

So, the minimization objective function is given by:

$$\text{Minimize} \quad B_n = C_{ip} - C_{prod}$$

2.3 Linear programming models (LP-MAX and LP-MIN)

In the linear programming models, the irrigation system lay-out was previously defined according to the experience of the designer. The optimization process only selects the combination of diameter to be used in the hydraulic network. The maximization and minimization models were based on the equations system developed by [Anonymous, 2002].

The variable annual volume of water applied per plant (W) was a component of non-linear equations that define several other variables in the objective function. Thus, the LP-MAX model considered W an input parameter and simulated the increase in B_n for different values of the annual irrigation volume per plant, aiming to establish a relationship between these two variables and find the optimal point.

3. APPLICATION OF THE MODELS

The models were used to design a microirrigation system for a citrus orchard in the state of São Paulo, Brasil. The area is 600 m × 400 m and the slope in the y-direction is 3%.

The nominal flow rate versus pressure curve for the microsprinkler adopted in this work is given by:

$$q = 9.8918h^{0.5326} \quad (76)$$

where q = microsprinkler discharge (L/h); and h = microsprinkler pressure (m).

The microsprinkler working pressure is 15.5m with an equivalent discharge of 43 L/h. The emitter coefficient of manufacturing variation from the manufacturer is 2.3% and the emission uniformity adopted is 90%.

3.1. Input data

The input data required by the models are shown in Tables 1 and 2. They describe hydraulic and operational conditions, equipment prices, design criteria, and irrigated area dimensions.

The lateral lines have a single diameter and use polyethylene pipes. Three diameters were analyzed in the NLP models : 13, 16, and 20 mm.

Table 1. Input parameters: values of the coefficient C_i of the equations.

C_i	Equation	Value
1	8	17.229
2	8	-0.0894
3	9	122.26
4	9	1.6599
5	10	193.19
6	10	1.7049
7	11	193.19
8	11	1.7049
9	12	193.19
10	12	1.7049
11	30	272.20
12	31	42.29
13	31	76.32
14	32	76.32
15	32	76.32

Table 2. Values of the input parameters.

Parameters	Value
Citrus price (US\$/kg)	0.0686
Number of trees per hectare	357
Production cost per kg	0.0417
Number of microsprinklers per tree, N_m	1
Spacing between lateral lines, S_m	4 m
Spacing between microsprinklers in the lateral line, S_L	7 m
Irrigation frequency, I_{FR}	3
Efficiency of application	90%
Maximum available time for irrigation	24h/day
Minimum available time for irrigation	18h/day
Slope gradient in the y-direction (m/m)	0.03
Microsprinkler price, C_m	US\$0.59/unit
Capital recovery factor, CRF , for a discount rate of 6% and an irrigation system life-cycle of 10 years	0.13587

Electricity price, E	US\$0.0476/kWh
Length of the field in the x-direction	392 m
Length of the field in the y-direction	576
Total area, A	225,792 m ²
Pump system efficiency, η	61.6%
Emitter coefficient of manufacturing variation, E_{mv}	0.023
Head loss in the control station, H_{es}	12 m
Head losses in the valves, H_v	2 m
Microsprinkler working pressure, q_w	15.5 m
Design emission uniformity, EU	90%
Microsprinkler discharge at the working pressure, q_w	43 L/h
Yield in rainfed condition (Y_r), in kg/ha yr (or 3 box/tree; 1 box =40.8kg and 357 trees/ha)	43,697

All the other lines used PVC pipes. In the manifold, the nominal diameters were 35, 50, 75, 100, 125, and the pressure rating is 40 m. In the auxiliary, submain, and main lines, the nominal diameters available were 50, 75, 100, 150, 200 for the 80 m class. Table 3 shows the pipe prices as a function of diameter and pressure class.

Table 3. Price of the PVC pipes as a function of diameters and pressure classes.

Pressure class (m)	Nominal Diameter (ND) (mm)	Price (US\$/m)
40	35	0.54
	50	0.75
	75	1.44
	100	2.31
	125	3.78
	150	5.37
80	75	2.14
	100	4.23
	150	8.45

In the case of the linear programming models (LP-MAX and LP-MIN), the layout must be previously defined. Adopting the pipeline with 13 mm of internal diameter in the lateral line that gives the lowest cost and respecting the emission uniformity desired, the system was designed by an experienced, containing 24 subunits, 4 submains, and 4 subunits working simultaneously (Figure 2).

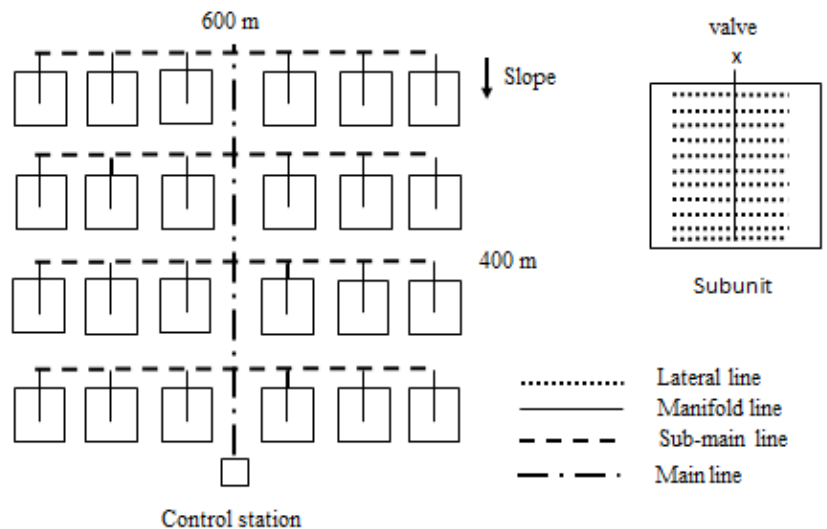

Fig. 2. Irrigation system layout with the 24 subunits adopted in the linear programming models.

There was considerable fluctuation in the citrus price. So, it was used the mathematical expectation of the price (US\$ 0.0686/kg).

The crop water production function (CWPF) was obtained using data from [18], and an equation was adjusted:

$$Y = -5.1466 \cdot 10^{-8}W^2 + 8.1133 \cdot 10^{-4}W + 2.7334 \tag{77}$$

with Y = yield with irrigation, in box (40,8kg) per tree; W = water applied in L per year, per tree ($2390 L \leq W \leq 14342 L$).

The average daily evapotranspiration in the peak period was $4 \text{ mm}\cdot\text{d}^{-1}$, and the number of days of irrigation during the annual critical period was 90 days. Once the orchard was established at a spacing of $4\text{m} \times 7\text{m}$ and considering the values of average daily evapotranspiration and duration of the peak period, the annual volume of water effectively applied per tree by irrigation was $10.08 \text{ m}^3\cdot\text{yr}^{-1}$.

The water use efficiency (WUE) was calculated by the ratio between citrus yield and total water depth applied (irrigation + effective rainfall). The citrus yield was the sum of the increase in the actual yield when irrigation is adopted (ΔY) and the yield in rainfed condition (122.4 kg/tree). The total water depth applied was the sum of the average effective rainfall in the region ($1,021 \text{ mm/yr}$ or $28.6 \text{ m}^3/\text{tree}\cdot\text{yr}$) and the irrigation depth obtained in each optimization model.

There is not an available solver to run the models with nonlinear variables that are simultaneously discrete. The solution is to run the model with some of them as continuous variables and, in a second step, based in the results obtained, built a linear model with the lay-out and operational conditions established by the primary nonlinear model, only optimizing the hydraulic networks with commercial diameters.

The GAMS [19] software version 2.50 solved the LP and NLP models.

4. RESULTS AND DISCUSSION

4.1. Design of the hydraulic network

The hydraulic network characterization for each optimization model is described in Table 4.

The layout and operational characteristics were previously established for the LP models as 24 operating units in the total, with 4 working simultaneously. So, the models defined the diameters combined in the hydraulic network, assuming that the manifold line is in a downhill condition.

Otherwise, the NLP models (maximizing and minimizing) defined 8 operational units (Figure 3), with only one operating at a time, adopting auxiliary and manifold lines in downhill and uphill conditions. They were efficient in defining the derivation line best insertion point of the auxiliary line. The uphill section of the manifold line had 38.5m ND75 and 35m ND50, while the downhill section had 52.5m ND75, 28m ND50, and 35m ND35, according to NLP-MAX model.

There are essential differences between LP and NLP models. The necessity to define the layout in the LP models becomes the optimization process restricted to establish the hydraulic network components (pipeline length and diameters used). Part of the process is dependent on the designer experience and the choices that he makes. The layout and the operation conditions are previously defined, and there is always subjectivity in this selection process, as also described by [Anonymous, 1996].

The nonlinear model gets local optimal, but it defines the layout, design, and management of the systems, with more chance to obtain a higher net benefit.

In all optimization models, the total pressure head was close to 55mca. The emission uniformity was 87% in NLP models and 90% in LP models.

Table 4. The hydraulic network characterization for each optimization model.

Item	NLP-MAX	NLP-MIN	LP-MAX	LP-MIN
Number of subunits	8	8	24	24
Number of subunits working simultaneously	1	1	4	4
Number of submains	2	2	4	4
Lateral line	70m ND16	70m ND16	46m ND13	46m ND13
Manifold line				
- Uphill	38.5m ND75 35m ND50	45.5 ND75 28m ND50	----	----
- Downhill	52.5m ND75 28m ND50 35m ND35	52.5m ND75 28m ND50 35m ND35	59.5m ND50 35m ND35	66.5m ND50 28m ND35

Auxiliary line				
- Section 1	72m ND100	72m ND100	----	----
- Section 2	72m ND100	72m ND100	----	----
Submain line				
Section 1	119m ND100	119m ND100	146m ND75 and 104m ND50	146m ND75 and 104m ND50
Section 2	196m ND100	196m ND100	167.5m ND75 and 82.5m ND50	167.5m ND75 and 82.5m ND50
Section 3	----	----	213.3m ND75 and 36.7m ND50	213.3m ND75 and 36.7m ND50
Section 4	----	----	250m ND75	250m ND75
Main line				
Section 1	144m ND100 (PC80)	144m ND100 (PC80)	98m ND100 (PC80)	98m ND100 (PC80)
Section 2	----	----	98m ND100 (PC80)	98m ND100 (PC80)
Section 3	----	----	98m ND100 (PC40)	98m ND100 (PC40)
Section 4	----	----	98m ND100 (PC40)	98m ND100 (PC40)
Total operating head (<i>HT</i>)	55.5m	55.3m	55m	54.8m
Emission uniformity (<i>EU</i>)	87%	87%	90%	90%

*ND: nominal diameter; PC=pressure class

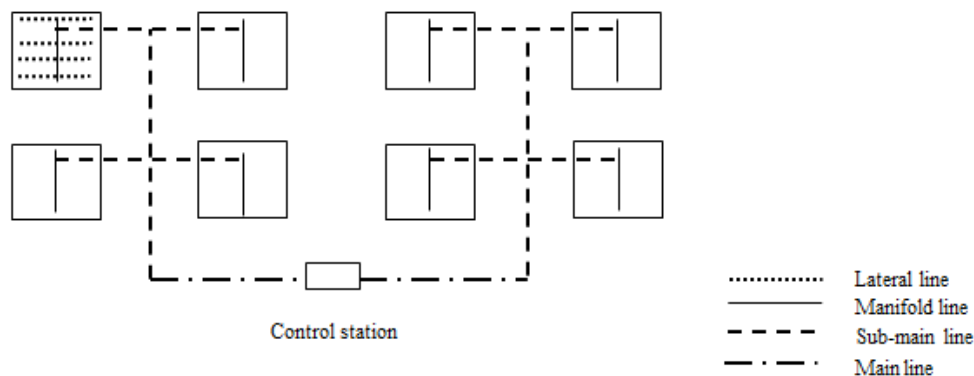

Fig. 3. Irrigation system layout obtained with the nonlinear programming models.

4.2. Productivity and economic performance of the LP and NLP models

The LP model for maximization considered W an input parameter and simulated the increase in B_n (Table 5) for different values of the annual irrigation volume per plant (2.390 / 4.780 / 7.170 / 7.500 / 7.865 / 7.882 / 8.000 / 9.560 / 11.952 / 14.342 m³). The second-degree polynomial equation (Figure 4) was found, representing the relationship between B_n and W . It allowed identifying the optimum solution for the LP-MAX model ($W = 8.000$ m³/tree and $B_n = \text{US}\$970.4/\text{ha.yr}$).

Table 5. Results of B_n as a function of W , adopted in the maximation LP model.

Volume of water per tree (W), in m ³ , during the critical season (90 days/yr)	Annual increase (B_n) in the irrigated crop net benefit(US\$/ha.yr)
2.390	430.9
4.780	817.3
7.170	968.7
7.500	969.4
7.865	970.1
7.882	970.2
8.000	970.4
9.560	896.6
11.952	588.8

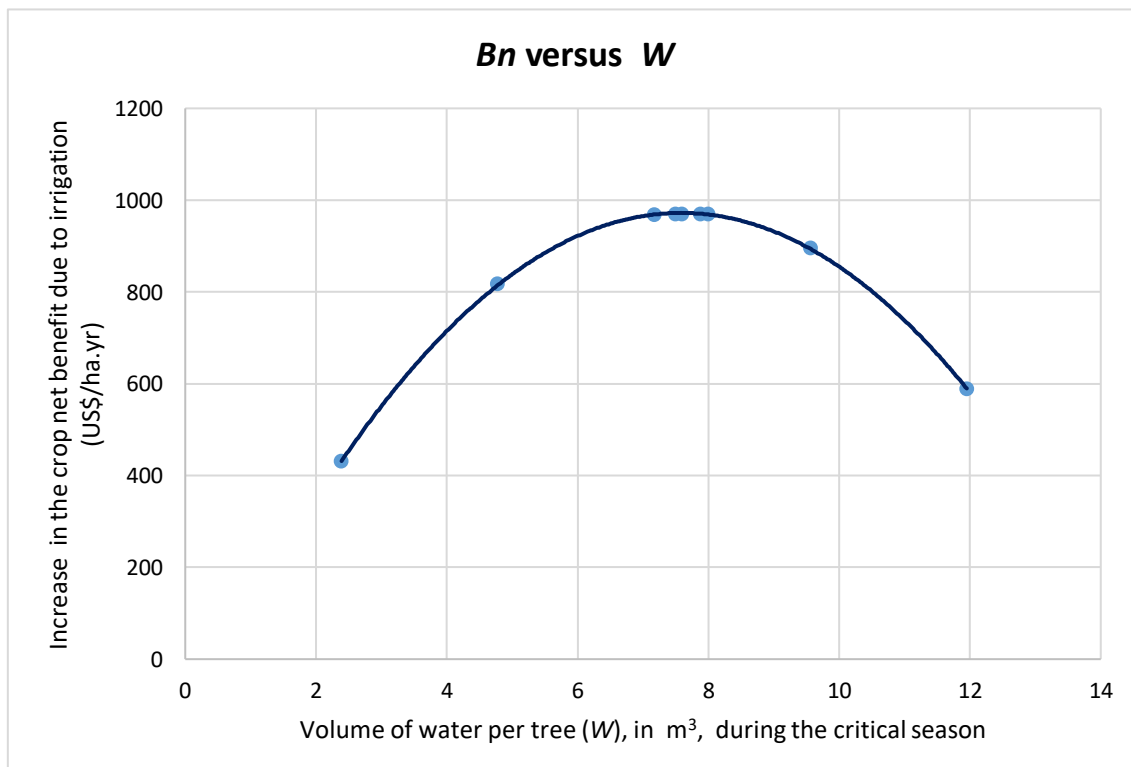

Fig. 4. Annual increase in the crop net benefit due to irrigation adoption (US\$/ha.yr) as a function of the annual volume of water applied per tree, in m³, obtained by simulation and associated with LP-MAX model.

The maximizing models have generated better results than minimizing models in terms of *B_n* and costs. Likewise, NLP models performed better than similar PL models (Table 6).

The most significant increase in *B_n* was obtained with the NLP-MAX with US\$ 1007.9/ha.yr. The second best option was the LP-MAX, US\$ 970.4/ha.yr, followed by the NLP-MIN, US\$ 881.0/ha.yr, and finally, by the LP-MIN (US\$847.0/ha.yr).

The design generated by the maximization NLP-MAX provided the most significant increase in net benefit, associated with the lowest water consumption, lowest cost of the hydraulic network, and lowest energy cost (Table 6) since it considers the CWPF in the optimization process. The second best option was obtained with the LP-MAX model, but with *B_n* 4% less than the NLP-MAX, volume of irrigation water and energy consumption 5% higher, in addition to the pipeline 19% more expensive.

The NLP-MAX model, compared to the LP-MIN, increased by 19% the *B_n* and decreased by 25%, 24%, 25%, and 20% the water consumption, energy cost, water cost, and pipeline cost, respectively.

The LP and NLP maximization models generated the most significant increases in *B_n* due to the possibility of using the crop water production function, expanding the universe of possible solutions considerably.

In most cases, the maximization of the net benefit is not equivalent to maximizing the yield, as described by [20]. The results corroborate this fact, once the maximum yield from the CWPF is obtained with *W* = 8.882 m³/tree.yr, which is equivalent to *B_n* of US\$ 970.2/ ha.yr.

In the minimization models, the volume of water to be applied must be defined in advance, resulting in the highest water demands in this research (Table 6) and the worst economic values.

Table 6. Productivity and economic performance of the NLP and LP models

Item	NLP Model		LP Model	
	Maximization	Minimization	Maximization	Minimization
Volume of irrigation water, in m ³ /tree.yr (<i>W</i>)	7.60	9.72	8.00	10.08
¹ Total volume of water, in m ³ /tree.yr	36.20	38.32	36.60	38.68
Increase in the actual yield when irrigation is adopted (ΔY), in kg/tree.yr	119.41	112.5	119.6	109.4
² Total yield, in kg/tree.yr	241.8	234.9	242.0	231.8

WUE (kg/m ³)	6.7	6.1	6.6	6.0
Energy (pump system) annual cost, US\$/ha.yr	38.6	49.1	40.4	50.7
Annual water cost, US\$/ha.yr	53.6	68.7	56.51	71.2
Pipeline cost, US\$/ha.yr	193.7	206.3	229.7	240.2
Annual increase of net benefit due to irrigation, US\$/ha.yr	1,007.9	881.0	970.4	847.0

¹ Considering the effective rainfall of 28.6 m³/tree.yr

² Considering the yield in rainfed conditions of 122.4 kg/tree.yr

The water use efficiency (WUE) was estimated by the ratio between the total yield and the total volume of water applied (Table 6). The highest WUE was obtained with the NLP-MAX model, followed by LP-MAX, NLP-MIN, and finally by the LP-MIN (Figure 6).

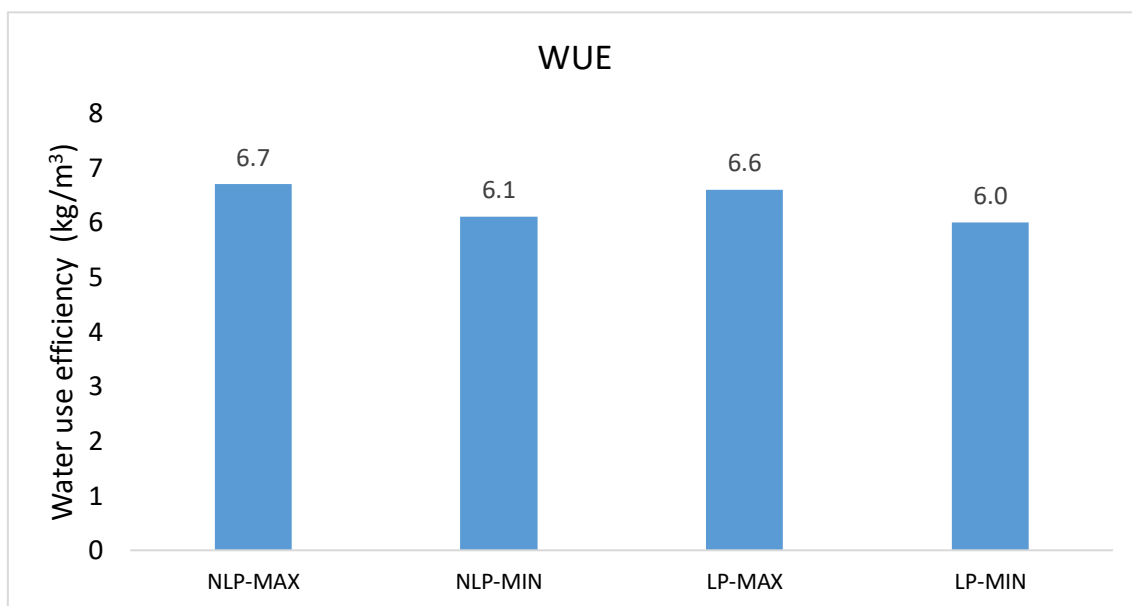

Fig. 5. Water use efficiency (WUE), in kg/m³, for the NLP-MAX, NLP-MIN, LP-MAX, and LP-MIN models.

The NLP model for maximization was a very appropriate option for microsprinkler irrigation systems design, defining operational conditions that maximize B_n and WUE, with an economy in the water consumption and the energy cost, as showed in Figure 6.

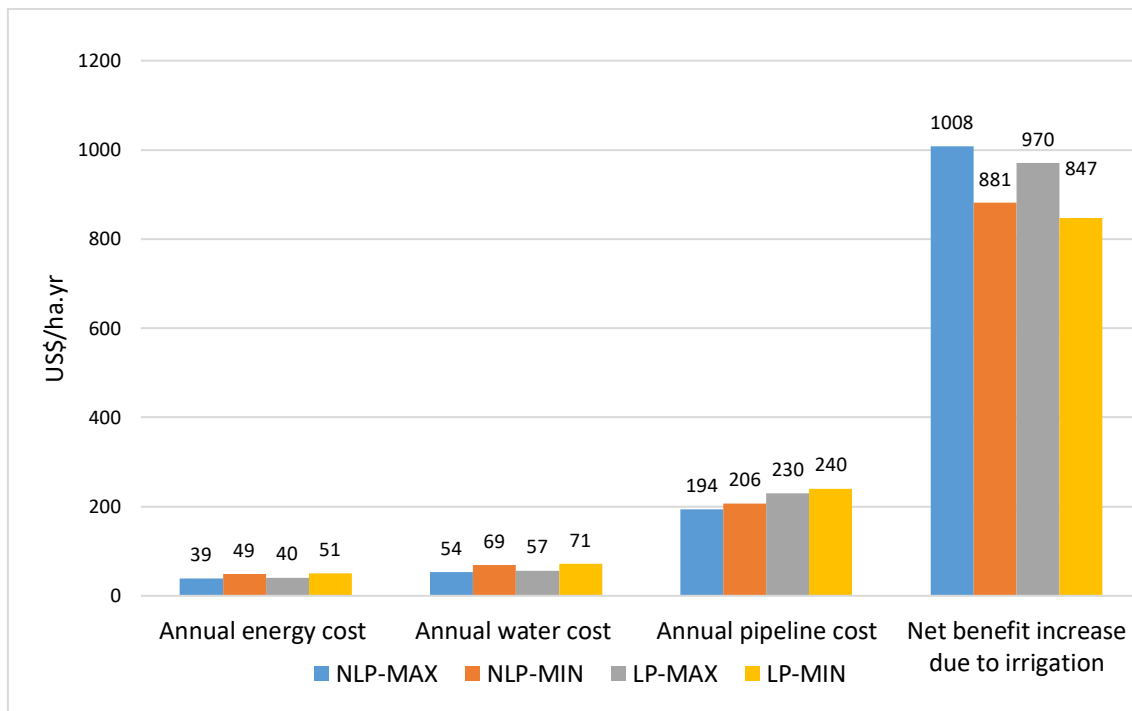

Figure 6. Annual energy cost, annual water cost, annual pipeline cost, and net benefit increase due to irrigation for the NLP and LP models.

5. CONCLUSIONS

The highest net benefit was found using the NLP model with the maximization criterion. The worst result was obtained with the LP model and the minimization of the total annual cost. The layout and management previously established by the designer are subjective and rarely results in the best solution, although the linear programming model always gets the global optimum. The NLP models get local optimal, but they defined the layout, design, and management of the systems, with more chance to obtain a higher net benefit.

The NLP model for maximization showed to be an adequate option for designing microsprinkler irrigation systems, defining the hydraulic network and the operational conditions that maximize *Bn* and WUE, with the lowest water consumption and lowest energy cost.

6. REFERENCES

[1] BAIAMONTE, G. Advances in designing drip irrigation laterals. *Agricultural Water Management* 2018, 199, 157-174.

[2] TAL, A. Rethinking the sustainability of Israel's irrigation practices in the Drylands. *Water Research* 2016, 90, 387-394.

[3] GARCIA NIETO, PAULINO JOSE & GARCÍA-GONZALO, E. & PUIG-BARGUÉS, JAUME & SOLÉ-TORRES, C. & DURAN-ROS, MIQUEL & ARBAT, G. A new predictive model for the outlet

turbidity in micro-irrigation sand filters fed with effluents using Gaussian process regression. *Computers and Electronics in Agriculture*. 2020, 170. 105292. [10.1016/j.compag.2020.105292](https://doi.org/10.1016/j.compag.2020.105292).

[4] KELLER, J., BLIESNER, R.D. *Sprinkle and trickle irrigation*. 1990. AVI Book, New York, USA.

[5] BAIAMONTE, G. Explicit relationships for optimal designing rectangular microirrigation units on uniform slopes: The IRRILAB software application. *Computers and Electronics in Agriculture* 2018, 153, p.151-168.

[6] VALIPOUR, M. Sprinkle and trickle irrigation system design using tapered pipes for pressure loss adjusting. *Journal of Agricultural Science* 2012, Vol. 4, No. 12, p.125-33.

[7] SADEGHI, SAYED-HOSSEIN & PETERS, ROBERT & SHELIA, VAKHTANG. Energy Grade Line Assessment for Tapered Microirrigation Laterals. *Journal of Irrigation and Drainage Engineering* 2016, 142. [10.1061/\(ASCE\)IR.1943-4774.0001020](https://doi.org/10.1061/(ASCE)IR.1943-4774.0001020).

[8] PLEBAN, S., AMIR, I. An interactive computerized aid for the design of branching irrigating networks. *Transactions of the ASAE* 1981, 24(2), 358-61.

[9] ORON, G., KARMELI, D. Solid set irrigation system design using linear programming. *Water Resources Bulletin*. 1981. 17(4), 565-70.

[10] '[Anonymous 1994] Details omitted for double-blind reviewing.'

[11] THEOCHARIS, M.E., TZIMOPOULOS, C.D., SAKELLARIOU-MAKRANTONAKI, M.A., YANNOPOULOS, S.I., MELETIOU, I.K. Comparative calculation of irrigation networks using Labye's method, the linear programming method and a simplified nonlinear method. *Mathematical and Computer Modelling* 2010, v. 51, p. 286-99, ISSN 0895-7177, <https://doi.org/10.1016/j.mcm.2009.08.040>.

[12] '[Anonymous 2002] Details omitted for double-blind reviewing.'

[13] HOLZAPFEL, E.A., MARIÑO, M.A., VALENZUELA, A. Drip irrigation nonlinear optimization model. *Journal of Irrigation and Drainage Engineering* 1990, 116(4), 479-96.

[14] '[Anonymous 1996] Details omitted for double-blind reviewing.'

[15] DANDY, G.C., HAASANLI, A.M. Optimum design and operation of multiple subunit drip irrigation systems. *Journal of Irrigation and Drainage Engineering* 1996, 122 (5), 265-75.

- [16] KANG, Y., NISHIYAMA, S. An improved method for designing microirrigation submain units. *Irrigation Science* 1997, 17, 183-93.
- [17] KARMELI, D., KELLER, J. Trickle irrigation design. *Rain Bird Sprinkler* 1975. Manufacturing Corporation, Glendora, California, USA.
- [18] BERTONHA, A., FRIZZONE, J. A., & MARTINS, E. N. Irrigação e adubação nitrogenada na produção de laranja-pêra. *Acta Scientiarum. Agronomy* 2008, 21, 537-542. <https://doi.org/10.4025/actasciagron.v21i0.4281>
- [19] BROOKE, A., KENDRICK, D., & MEERAUS, A. *Gams: A User's Guide*, Release 2.25 1992, Boyd & Fraser Publishing Company, Danvers.
- [20] BRUMBELOW, K.; GEORGAKAKOS, A. Determining crop-water production functions using yield-irrigation gradient algorithms, *Agricultural Water Management* 2007, v.87, p.151-161, ISSN 0378-3774, <https://doi.org/10.1016/j.agwat.2006.06.016>.

7. APPENDIX A. NOTATION

The following symbols were used in this paper:

A = regression coefficient;

APM = maximum allowable pressure head variation in the manifold line (m);

$APVS$ = allowable pressure head variation in the subunit (m);

At = total area (m^2);

B = regression coefficient;

B_g = annual increase in the crop gross benefit due to irrigation adoption (US\$/ha yr);

B_n = annual increase in the crop net benefit due to irrigation adoption (US\$/ha yr);

$C_1, C_2, C_3, C_4, C_5, C_6, C_7, C_8, C_9, C_{10}, C_{11}, C_{12}, C_{13}, C_{14}, C_{15}$ = constants;

C = regression coefficient;

CCP = cost (US\$) of control panel;

CF = cost (US\$) of filter system;

C_{ip} = annual cost with investment and pumping (cost of irrigation system) in US\$/ha.yr;

C_{kw} = cost of kWh (US\$);

C_{mi} = microsprinkler cost (US\$/unit);

CP = cost (US\$) of the pump station;

C_{pb} = production cost without irrigation (US\$/kg);

C_{pe} = cost (US\$/m) of polyethylene pipe expressed as a function of the diameter (m);

CPP = annual pumping cost (US\$/yr);

C_{prod} = annual production cost (except irrigation) (US\$/ha yr);

C_{pva} = cost (US\$/m) of PVC pipe expressed as a function of the auxiliary line
 C_{pvm} = cost (US\$/m) of PVC pipe expressed as a function of the manifold line diameter (m);

C_{pvn} = cost (US\$/m) of PVC pipe expressed as a function of the main line diameter (m);

C_{pvs} = cost (US\$/m) of PVC pipe expressed as a function of the submain line diameter (m);

CRF = capital recovery factor;

CV = cost (US\$) of valves;

CW = water cost (US\$/yr);

D = inside diameter of the pipe (m);

DA = auxiliary line diameter (m);

DL = lateral line diameter (m);

DM = manifold line diameter (m);

DN = main line diameter (m);

DS = submain line diameter (m);

E_a = application efficiency;

E_{MV} = manufacturing variation in emitter expressed as a coefficient of variation;

EU = emission uniformity (expressed as a decimal);

FA = the Christiansen's coefficient for the auxiliary line;

FL = the Christiansen's coefficient for the lateral line;

FMD = the Christiansen's coefficient for the downhill manifold line;

FMU = the Christiansen's coefficient for the uphill manifold line;

FN = the Christiansen's coefficient for the main line;

FS = the Christiansen's coefficient for the secondary line;

h = microsprinkler pressure (m);

H_{AV} = average pressure head in the subunit (m);

HCS = head loss in the control station (m);

H_f = head loss due to pipe friction (m);

HFA = auxiliary line head loss (m);

HFL = lateral line head loss (m);

$HFMU$ = uphill manifold line head loss (m);

HFN = main head loss (m);

HFS = submain head loss (m);

HMD_g = pressure head at the outlet g of the manifold line (m);

HMD_j = pressure head at the outlet j of the manifold line (m);

HM_o = pressure head at the inlet of the manifold line (m);

H_{MIN} = pressure head that will give the minimum emission rate in the subunit (m);

HMU_{end} = pressure in the last outlet of the uphill manifold;

HT = total head losses plus the total difference in elevation (m);

I_d = number of irrigation hours per set of subunits working simultaneously, during an irrigation interval;

I_f = number of days in the irrigation interval (irrigation frequency);

I_h = number of irrigation days during the year;

JP = manifold position ratio, which gives the same minimum uphill and downhill pressure head along a pair of manifolds;

L = length of pipe (m);

LL = lateral line length (m);

LM = manifold line length (m);

LMD = downhill manifold line length (m);

LMU = uphill manifold line length (m);

L_x = length of field in the x-direction (m);

L_y = length of field in the y-direction (m);

NLL = number of outlets in the manifold;

$NLLD$ = number of outlets in the downhill section of the manifold line;

$NLLU$ = number of outlets in the uphill section of the manifold line;

N_m = number of emitters per emission point;

NML = number of emission points in a lateral;

NSU = number of subunits;

P = product price (US\$/kg);

P_w = water price (US\$/m³);

Q = flow rate in the pipe (m³/s);

q = microsprinkler discharge (L/h);

QA = auxiliary line discharge (m³/s);

QL = lateral line discharge (m³/s);

QMU = uphill manifold line discharge (m³/s);

QN = main line discharge (m³/s);

q_{MIN} = minimum emission rate in the subunit (m³/s);

QS = submain line discharge (m³/s);

Q_{SU} = operational subunit discharge (m³/s);

q_w = average emitter discharge (m³/s);

S_L = distance between lateral lines (m);

S_M = distance between emission points in a lateral line (m);

T_{av} = number of hours available for irrigation per day;

TAL = auxiliary line total length (m);

TLL = lateral line total length (m);

TM = total number of microsprinklers;

TNL = total length of main line (m);

TSL = submain line total length (m);

VA = velocity in the auxiliary line (m/s);

VN = velocity in the main line (m/s);

VS = velocity in the submain line (m/s);

W = annual volume of water applied per plant, in L ($2390 L \leq W \leq 14342 L$);

Y = crop yield with irrigation, in kg/ha yr;

Y_r = yield in rainfed condition (kg/ha yr);

ΔY = increase in the actual yield when irrigation is adopted (kg/ha.yr);

η = pump and motor efficiency;

Copyright Disclaimer

Copyright for this article is retained by the author(s), with first publication rights granted to the journal.

This is an open-access article distributed under the terms and conditions of the Creative Commons Attribution License (<http://creativecommons.org/licenses/by/4.0/>).