

An Analog Circuit Course Teaching Method Based on the Analysis of Classic Application Circuits

Qing Xiang (Corresponding author)

School of Intelligent Manufacturing, Jiangnan University,
430056, Wuhan, China.

Abstract

Analog circuit course is a compulsory professional basic course for engineering majors such as automation and electronic information engineering. Since traditional teaching methods cannot enable students to effectively master the knowledge of analog circuits, this article proposes a teaching method of analog circuits based on the analysis of classic application circuits, including the idea of selecting classic application circuits, "impression enhancement method of "reading, drawing and memorizing circuit diagram" and hands-on implementation of classic circuits. Through the practice of teaching reform for one semester, the results show that the teaching method enhances students' enthusiasm for learning, enables students to integrate theoretical knowledge, deeply understand application circuits, and then carry out practical applications or innovate on this basis.

Keywords: teaching method; analog circuit course; classic application circuit

1. Introduction

The analog electronic technology course is a compulsory professional basic course for automation, electronic information engineering, and other electrical engineering majors. It is a practical course that closely combines theory and practice to strengthen students' electronic technology practice capabilities. In traditional teaching, teachers mainly explain the theory step by step in accordance with the chapters of the textbook. Students often cannot analyze an actual comprehensive circuit after learning, so they cannot adapt to the requirements of electronic engineers from enterprises. With the development of modern science and technology, teaching methods are constantly changing, and various classroom presentation forms such as multimedia courseware, Flash animation, software simulation, etc. can be used. Although these information-based teaching methods are very popular, the classroom learning process still cannot get rid of the methods of teacher explanation, teacher operation, and teacher demonstration, and cannot stimulate the students' enthusiasm and subjective initiative. The main problems boil down to the fact that basic courses, theoretical courses, and application courses are not well integrated with application practice needs, and students cannot participate in active learning.

In order to improve the enthusiasm of students in the course of analog circuit teaching, stimulate their interest and potential in learning, enable students to integrate the knowledge of each chapter, and improve students' practical ability, this article proposes an analog circuit teaching method based on classic

application circuit analysis. By comparing the quantitative indicators of students' learning outcomes after traditional teaching and improved teaching methods, it can be seen that the teaching method has achieved better results.

2. Teaching method based on analysis of classic application circuits

The teaching method based on the analysis of classic application circuits has higher requirements for teachers. Teachers need to select and explain the classic circuits that fit the content of the textbook and related to practical applications, guide students to read circuit diagram, draw circuit diagram, and record circuit diagram to lay a good foundation and enable students to further understand the circuits through experiments, so that students can learn analog circuit courses well and make innovations in practical applications.

2.1 Select classic application circuits as teaching materials

The teaching materials of analog circuit course are often arranged separately according to the content of diodes, transistors, operational amplifiers, etc. Teachers generally teach theoretically in accordance with the order of chapters. After finishing teaching a chapter, teachers will test or assign homework for the content of the chapter. Therefore, when students encounter practical applications, such as participating in some electronic design competitions, they feel that they have not learned much of the practical content in the analog circuit course, and they are confused when they encounter the debugging of actual circuit. In fact, the analog electronic technology course is a combination of theory and practice. It cannot be mastered in depth by relying on textbooks alone. If some key circuits in practical applications are selected for explanation, students can link the knowledge of each chapter. It is easier to integrate theory with practice, and to encourage students to stimulate their own innovative thinking based on learning and understanding.

Teachers need to keep up with the times and collect some application analog circuits as teaching materials which can be from internet, journals or books. By selecting classic electronic circuit design cases from these materials, teachers can combine different teaching contents and chapters of the textbook to carry out teaching.

According to the teaching content of analog circuit course and practical application, the teaching materials can be collected and organized roughly through the following five basic categories: 1), separate component design circuit; 2), analog integrated chip design circuit; 3), digital logic chip design circuit; 4), separate integrated hybrid design circuit; 5), single-chip hybrid design circuit.

In order to meet the teaching requirements, the classic circuit can be selected according to the following ideas:

- 1) The selected circuit is a comprehensive application of the content of all or part of the units in the textbook;
- 2) The selected circuit has innovative design;
- 3) The selected circuit has strong applicability,
- 4) The selected circuit is highly inspirational.

Figure 1 is a classic analog integrated chip circuit case collected based on the above ideas. The circuit

is simple and clear, but the knowledge points covered are very rich, closely linked to multiple teaching points in the book. The realization and debugging of this circuit are very simple, and the practical application is extensive. Through this case, the students can further move from "theoretical circuit and ideal circuit" to the design and application of "application circuit".

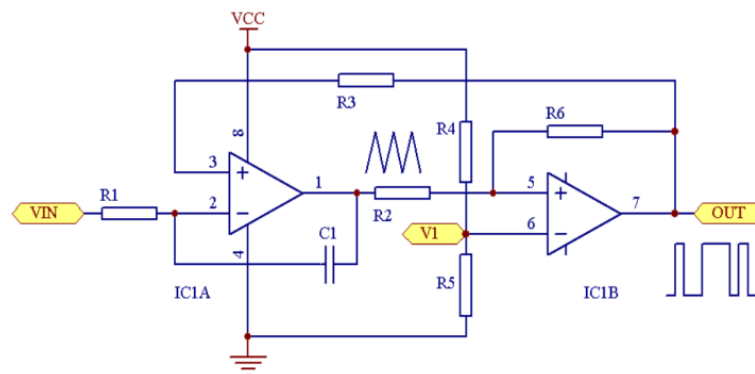

Figure 1. A voltage-controlled PWM pulse width modulation circuit designed by a classic operational amplifier

The reasons for choosing this case circuit are detailed below.

1) First of all, a basic combination design concept can be established through an ideal operational amplifier. Take a typical circuit (such as $\mu A741$) as an example, it can be used for students to analyze and understand the components and working principles of the circuit, and master the important components of the multi-stage direct coupling amplifier of the differential amplifier. In addition to mastering its working principle, students should also pay attention to calculating various indicators based on "Ideal circuit". For the internal units of the new circuit, teachers can give a focused introduction and indicate the direction of development. Emphasis is placed on the main technical indicators, functional meanings and application scenarios, so that the correct model can be selected when designing the circuit.

2) Through application circuit case analysis, teachers can focus on application circuits such as operational amplifiers, comparators, integrators, pulse width modulators, triangle wave generators, square wave generators, etc. Introducing the actual design circuit leads to more knowledge concepts of the analog circuit course.

2.2 Impression-enhancing teaching

Most of the analog circuit course teaching decomposes the circuit into the smallest unit or equivalent circuit for teaching and involving many theoretical derivations, which is lack of enlightenment. It ignores the practical working principle under the complete circuit. The teaching method of "Reading, Drawing and Memorizing circuit diagram" can help students deepen their understanding and memory, and facilitate practical application in the future. To read the circuit diagram is to understand the ins and outs of circuit design in detail; to draw circuit diagram is to practice hands, eyes, and brains; to memorize circuit diagram is to remember some commonly used circuits so that they can be quickly used when developing and designing projects application. By carrying out impression-enhancing teaching by reading, drawing and memorizing circuit diagram, students can be familiar with circuits and principle derivation.

1) How to read the circuit diagram? To understand the circuit diagram is to grasp the working principle and working process of the circuit. So reading circuit diagrams is actually an essential part of the process of learning circuit principles. The circuit diagram needs to follow the design concept of the circuit, according to the circuit principle, according to the work flow, according to the circuit structure, according to the circuit layout, according to the circuit type, from input to output, from power supply to load.

2) How to draw circuit diagrams? There are generally two ways, one is manual drawing, and the other is software drawing. Due to the large amount of teaching and learning, the drawing of circuit diagrams is basically handed over to the computer software to complete, and student learning by drawing circuit diagrams by hand is discarded. Lack of using hands and brains in circuit learning will result in the lack of deep understanding and memory of circuit diagrams in analog circuit learning, and even some students forget the circuits they have just learned. In fact, manual drawing is still very important in the study of analog circuits. In the future, the basic skills will become very important when solving practical problems on the spot in the work.

3) How to memorize circuit diagrams? The process of drawing diagrams is equivalent to enhancing memory. The purpose of memorizing circuit diagrams is to be able to apply them flexibly in the process of learning and practice, and to establish students' own circuit diagram memory bank, which can be remembered in the future, either to use the circuit or to design a new circuit based on the circuit.

Take Figure 1 as an example to illustrate the importance of "Reading, Drawing and Memorizing circuit diagram". It can be seen that this circuit is composed of two operational amplifier units IC1A and IC2B integrated circuits (represented by block diagram symbols). The first part is composed of operational amplifier IC1A to form an integral circuit. The RC forms a time constant network and the feedback capacitor achieves voltage-controlled integration to generate a fixed-frequency triangular wave output. The second part is a Schmitt trigger, or comparison trigger, composed of an operational amplifier IC2B. The comparison threshold voltage V_1 is set by R_4/R_5 , and a square wave oscillator is formed by the second-stage output and R_3 feedback. It can be seen that reading, drawing, memorizing and analysis of this case bring students into the core knowledge of the textbook, deepen the understanding of the principle of operational amplifier, integrator, RC time constant network, comparator, Schmitt trigger, triangle wave, square wave and PWM modulation circuit. This is our true teaching purpose.

2.3 Classic circuit analysis and hands-on implementation

In traditional analog circuit teaching, when students study a complete course, they often still feel a mess. They don't have a complete concept in their minds. They cannot integrate what they have learned and form a solid knowledge store.

Therefore, in the teaching process, we provide students with a classic circuit and application scenario from the beginning, so that students have an overall impression, and then use our previous teaching methods combined with the theoretical knowledge of textbooks to guide learning, which can enable students to better understand and analyze the key and difficult points in analog circuit learning, and enhance students' interest in learning and the ability to comprehensively apply basic knowledge, thereby improving the quality of analog circuit teaching.

In the PWM modulation circuit designed by the operational amplifier in Figure 1, through a simple

circuit analysis, it is not difficult to understand that IC1 is connected to a voltage-controlled integrator circuit, and the voltage control at the input terminal determines the integral charging rate of capacitor C1. IC2 constitutes a Schmitt trigger. The comparator circuit compares and outputs by setting the comparison voltage and the input voltage. Two-stage op amp cascade feedback to realize a typical analog PWM pulse width modulation circuit, if IC2B output is low, the output voltage of IC1A gradually drops to below the threshold voltage V1, then the output of IC2B becomes High level, at the same time, the output level of the integrator is increased by feedback R6 until it reaches the upper limit of the threshold, and the output becomes high immediately. Changing the input voltage of the inverting input terminal of IC1 can change the characteristics of the integrator. Because the threshold voltage V1 is fixed, the output pulse repetition period has changed, and the square wave change value can achieve a 0-100% change, but the frequency remains constant.

After basic analysis of the classic application circuit, teachers can put relevant reference materials on the online learning platform of this course, so that students can think about the circuit in detail after class, and use the devices and experimental platform provided by the university to carry out the circuit.

Practical courses should carry out practical activities, teaching guidance and practical guidance according to the aspects of students' interest-oriented, application-oriented, behavior-oriented, demand-oriented, and ability-oriented based on the classic circuit learning. Practical activities can be carried out independently in time and subject.

3. Practical application results of this teaching method

The analog circuit course of our university starts in the third semester, and majors in automation, measurement and control (MC), and electronic information engineering (EE) will start at the same time. The major of measurement and control is selected as a teaching reform pilot, while other majors are temporarily taught by traditional methods. Extracurricular learning and reference materials are uploaded on the university's online teaching platform, which is open to students in all classes as SPOC (Small Private Online Course). After a semester of study, the learning dynamics and results of a class of measurement and control major (38 students in total) and a class of electronic information engineering major (40 students in total) were compared. The results are as follows.

3.1 Comparison of student learning activity

The analog electronic technology course has a total of 56 class hours, 4 class hours per week, and a total of 14 weeks. The number of independent learning by students on the school's online education platform per week is used as a quantitative indicator of learning activity. Then in the fall semester of 2019, the data given by the university's online teaching platform is shown in Figure 2. The results show that the students of the measurement and control major are more active in learning, indicating that this teaching method uses classic application circuits as examples, and connects various knowledge points through analytical circuits to make it easier for students to understand; through the early stage of reading, drawing, and memorizing circuit diagram for students, the exercise enables students to lay a good foundation and can independently think about the principle details of classic application circuits under the inspiration of

teachers. After class, they can further analyze and calculate related indicators of circuits by consulting the reference materials provided by teachers on the online platform. The realization of the classic application circuits improves students' enthusiasm and autonomy in learning. And in the later stage, when the application circuit cases provided by the teacher are more complex and comprehensive, the number of students' autonomous learning increases significantly, which reflects the students' re-learning of the previous content to a certain extent, and this is conducive to the students' understanding of complex circuits. From the figure, it also can be found that in 5 weeks, the study times of the students majoring in electronic information engineering is less than the number of students in this class, indicating that some students in the class who usually have poor self-learning ability do not want to invest time after class. The average study times of EE students is 47% lower than MC students. This shows that using the traditional teaching method to explain the principles in the order of chapters, the process of passive reception by students is poor in mobilizing students' learning enthusiasm; although some basic reference materials are provided, teachers' guidance is lacking and students' basic skills are not solid, so they are not motivated to learn independently.

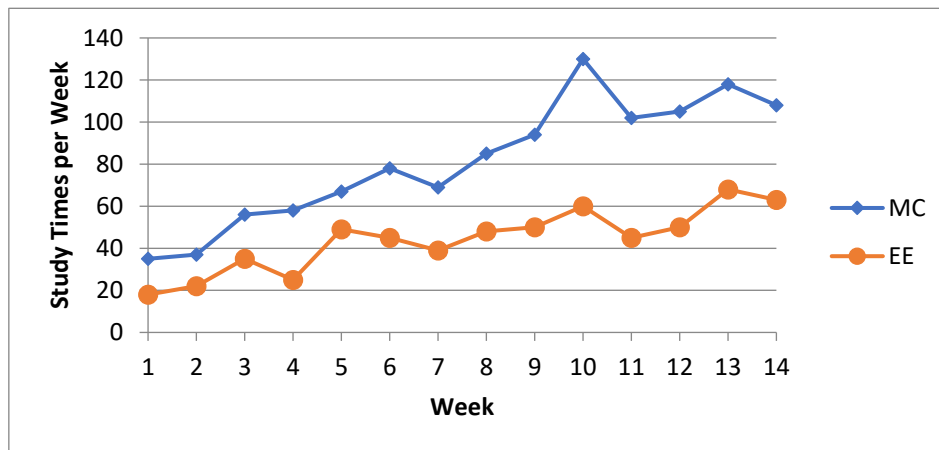

Figure 2. Comparison of learning activities of the students majoring in measurement control and electronic information engineering.

3.2 Comparison of student performance

The final exams of the two classes use a unified written test paper for closed-book examinations, with a total score of 100 points. The test results of the two classes are shown in Figure 3. As shown in the figure, the failure (with a score of less than 60) rate of the MC students (4.5%) is lower than that of EE students (8.2%); the excellent (90-100 points) rate (9.2%) of the MC students is higher than that of the EE students (4.6%); for the proportion of the population with good results in the 80-89 subarea, the MC major is higher than the EE major; and for the middle level (70-79 points) range, the proportion of students of the two majors are basically the same. After implementing the teaching method based on classical application circuit analysis, due to the improvement of students' learning initiative, enthusiasm and practical ability, the final grades of students of measurement and control are better than those of electronic information engineering who have not implemented this teaching method.

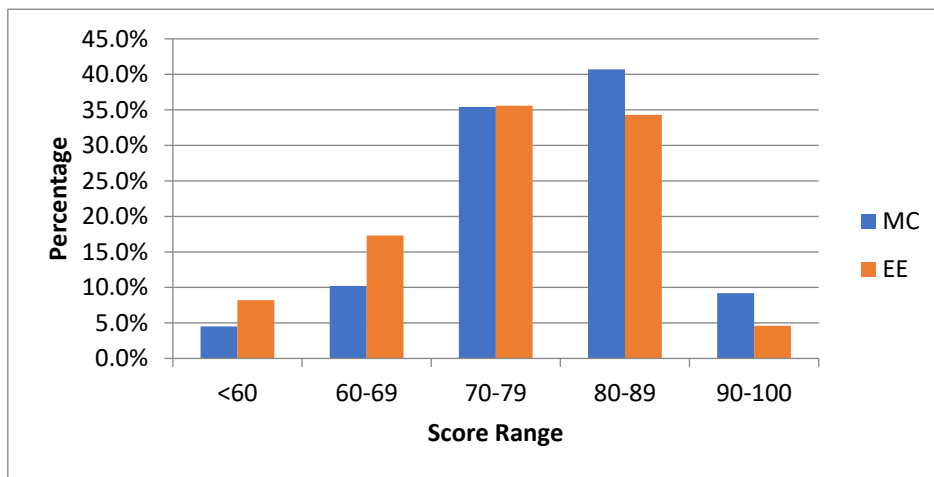

Figure 3. Comparison of test performance of the students majoring in measurement control and electronic information engineering.

4. Conclusion

The analog circuit course is a professional basic course for electrical and related majors. This course has the characteristics of combining theory and practice. It is a professional basic course for learning basic analog electronic devices, electronic circuits and electronic system analysis and design. The teaching method based on the analysis of classic application circuits proposed in this paper emphasizes the learning, consolidation and expansion of students' basic knowledge. First, carefully select the application circuits that cover the important knowledge points of the textbook, and then teach students to read, draw, and memorize the circuit diagram, so that students can deeply understand the application circuit and form a deep impression, which is convenient for designing actual electronic systems for direct use or innovation on this basis. Since the selected circuits have specific application backgrounds, students have specific goals and enthusiasm for self-study/review and hands-on realization after class, which is very important for learning analog circuits well. Through the comparison of learning activity and academic performance between the class that implements the teaching method and the class that does not implement the teaching method, it is found that the learning effect of the class that implements the teaching method is better than that of the non-implemented class.

5. References

1. Dogan Ibrahim. A New Approach for Teaching Microcontroller Courses to Undergraduate Students. *Procedia - Social and Behavioral Sciences*, 2014, 131: 411-414.
2. Harun Chowdhury, FirozAlam, Israt Mustary. Development of an innovative technique for teaching and learning of laboratory experiments for engineering courses. *Energy Procedia*, 2019, 160: 806-811.
3. Junbo Chen, Hui Zhou, Dandan Yang, Huimin Cao. Exploration on the Teaching Reform of "Analog Electronic Technology" under the Background of New Engineering. *Journal of Electrical & Electronic*

Education, 2020, 42(03):41-44+48.

4. Jing Chen, Xuefei Shi. Teaching Reform and Practice of "Analog Electronic Technology" Course. Higher Education of Sciences, 2020, (03): 119-123.

Copyright Disclaimer

Copyright for this article is retained by the author(s), with first publication rights granted to the journal.

This is an open-access article distributed under the terms and conditions of the Creative Commons Attribution license (<http://creativecommons.org/licenses/by/4.0/>).