

## **Development and Validation of a Hybrid Active Learning Strategy for Teaching Direct Current Electricity Concepts for Secondary Schools in Nigeria**

**Uche Connie Ofodile**

Federal Education Quality Assurance Services,  
Federal Ministry of Education, Abuja, Nigeria.

E-mail: [uchedile16@yahoo.com](mailto:uchedile16@yahoo.com)

**Mangut Mankilik**

Department of Science and Technology Education,  
University of Jos,  
Jos, Nigeria.

E-mail: [mankilikmangut@yahoo.com](mailto:mankilikmangut@yahoo.com)

### **Abstract**

*The study was carried out to develop and validate a Hybrid Active Learning Strategy (HALS) for teaching direct current electricity concepts (DCEC) in physics for secondary schools in Nigeria. The relevant literature reviewed revealed that the inappropriate use of relevant teaching strategies and the non-use of modern innovative technology in the teaching of physics result in lack of better understanding of concepts and hence, the poor performance of students in physics. In view of this, the HALS package which is a combination of active learning strategies including computer simulation was developed to help teachers to be more effective and students to understand DCEC concepts better. The developmental platform for the package is Microsoft visual basic 6. Other applications used during the design process include Adobe (macromedia) Director, Flash 8, Fireworks and Flash Player for animation, construction and display. The validation of HALS Package was done applying: subject content validation, computer expert validation, educational technology expert validation, personalized validation and group validation. The HALS package is generally perceived as very educative, comprehensive, adequate, relevant, user friendly and loaded with a lot of ingenuity.*

**Keywords:** *Hybrid Active Learning Strategy (HALS); Direct Current Electricity Concepts (DCEC); Development; Validation; Secondary School; Simulation.*

### **Introduction**

Physics generates the fundamental knowledge needed for the future technological advancement of any nation. Physics is both significant and influential, as advances in its understanding have often translated into new technologies which have dramatically transformed modern-day society. Such technologies include; television, computers, mobile phones, iPods, medical imaging system, fibre-optics and a host of other devices and systems that make use of basic direct current electricity principles. Thus physics is one of the core science courses offered at the senior secondary school level as stated in the National Policy on Education (FRN, 2004) and it forms the basis of the nation's advancement and human resource development (Abubakar, 2012). In realisation of the importance of science and technology, especially physics, the Nigerian government has taken a number of steps towards its improvement. These steps include the launching of two space satellite systems, the NigerSAT and the NIGCOMSAT in 2011. The NigerSAT focuses on weather observations while the NIGCOMSAT focuses on telecommunications. Also, the implementation of the Science and Technology Education Post Basic (STEP-B) project with support from the World Bank focuses on the production of more

and better qualified science and technology graduates. Furthermore, the review of the Senior Secondary School Physics Curriculum in 2011 to include Physics in Technology is a significant step towards the improvement of science and technology in Nigeria. Thus, the realization of Vision 20-2020 in Nigeria entails rapid production of the workforce that is versatile in the development of modern technologies which are based on the principles of direct current electricity. Despite the efforts of the Nigerian government, researchers generally observed low enrolment and poor performance of students in physics (Adegoke, 2011; Udoh, 2012; Erinosh, 2013; Gambari & Yusuf, 2014). This situation is of concern to the generality of people most especially physics educators and researchers (Adeyemo, 2010). The low enrolment and poor performance of students in physics is indicative of a serious variance between the expectations of the Nigerian Government as spelt out in the National Policy on Education (NPE) and the actual situation of physics in our schools and calls for a critical look at the strategies for the teaching and learning of physics (WAEC, 2008).

In an effort to unravel the causes of low enrolment and poor performance and also finding out that the mode of delivery of physics lessons in senior secondary schools in Nigeria is generally by expository, Akinbobola (2009, p.3) concluded that “the expository method is a teacher-centered, student-peripheral teaching approach in which the teacher delivers a pre-planned lesson to the students with or without the use of instructional materials”. In agreement with the low enrolment of students in physics, the West African Examinations Council (WAEC) analysis shows that in Nigeria between 2006 and 2014, on the average, about 35% of the total students who registered for West African Senior School Certificate Examinations (WASSCE) entered for physics. In terms of performance, the WAEC Chief Examiner’s reports (2005-2013) in physics indicated poor performance of students generally despite the favourable standards of the paper and the moderate severity of the marking scheme. In Kaduna State of Nigeria, the situation is not different. The low enrolment and poor performance of students in Kaduna State in physics has been attributed to inadequate human and material resources as well as inappropriate presentation of materials as recorded in the analysis of the education sector conducted by Kaduna State Ministry of Education (KSMOE, 2008). The situation is further compounded as the teaching of physics (direct current electricity) in senior secondary schools, is adversely affected by problems such as perceived abstract and difficult nature of direct current electricity concepts (DCEC), lack of modern equipment and poor teaching strategies.

Direct current electricity concepts (DCEC) are the underlying concepts of one of the units of study in physics dealing with the steady flow of electrons around a circuit. The concepts include those of current, voltage, potential difference and resistance in an electric circuit. DCEC are chosen because their principles are the basis of all modern technologies unlike other concepts in Senior Secondary School Physics Curriculum. Furthermore, direct current electricity is an area of physics that teachers find difficult to teach due to its abstract nature and students make a lot of mistakes in answering questions on it (Baser & Durmus, 2010). Furthermore, they stated that instructional materials should be developed to promote the development of basic scientific reasoning skills. To this end, in any teaching method, all efforts should be directed at the students’ better understanding of concepts being taught (Akinbobola & Afolabi, 2010). Thus, Bello (2011, p.73) puts it this way “the way physics is presented to students will inevitably affect its understanding by students and consequently how they relate to science in general”. In this light, visualization of phenomena through computer simulations can contribute to students’ better understanding of physics concepts (Zacharia & Olympiou, 2010). In the same vein, cooperative learning as an active learning strategy which involves students interactively working in groups to accomplish a common goal, brings about deeper understanding of learned task that is relevant to life after school (Bello, 2011). However, a number of lapses have been observed in the application of active learning strategies. The lapses include lack of use of a combination of active learning strategies which are recommended in order to have a better student engagement and interest (Afolabi & Akinbobola, 2009; Adeyemo, 2010). Some researchers attested to the dearth of relevant instructional computer software packages in the school system that will help students learn effectively (Oyelekan & Olorundare, 2009; Okorie, 2014). Therefore, it might be necessary to

critically study ways of applying a combination of active learning strategies which may enhance students' understanding of physics concepts especially direct current electricity concepts at the secondary school level. Based on the aforementioned, this study focuses on the development and validation of a computer simulation package named Hybrid Active Learning Strategy (HALS) for teaching DCEC to senior secondary school students in Nigeria. The HALS package was a combination of strategies of computer simulation, cooperative learning, questioning, class discussion, manipulation, exploration and experimentation. It was structured to be highly interactive, engaging and to create a learning environment with animated visual feedback to the user.

## **Statement of the Problem**

The inappropriate use of relevant teaching strategies and lack of modern innovative technology in teaching physics, especially, direct current electricity concepts (DCEC) have been major concerns of physics educators. Specifically, the defective methodology employed, as well as, non use of modern equipment during instruction generally leads to low enrolment and poor performance of students in physics (Adegoke, 2011). This implies that the way learning materials are presented to the students manifests in their non-active participation in learning, lack of interest and proper understanding of concepts. DCEC are central to the subject area of physics and the principles are core to all technological developments which makes it important that students understand and apply the principles in solving problems. In addition, the abstract nature of concepts in electricity might require the use of appropriate and relevant teaching strategies to enable students understand the concepts better. To this end, the researchers developed and validated an interactive computer based teaching strategy named Hybrid Active Learning Strategy (HALS) involving computer simulation, cooperative learning, questioning, class discussion, manipulation, exploration and experimentation for the teaching of DCEC in Nigerian secondary schools.

## **Purpose of the Study**

The purpose of this study was to:

1. design and develop HALS as a computer based strategy for the teaching of DCEC.
2. validate the HALS developed for the teaching of DCEC in secondary schools in Nigeria
3. find out the performance level of students in DCEC when taught using the HALS.

## **Research Questions**

The following research questions guided the conduct of this study:

1. What are the steps taken in the development of Hybrid Active Learning Strategy (HALS)?
2. How was the developed HALS package validated?
3. What are the performance levels of students in DCEC when taught using HALS.

## **Research Methodology**

This study was a design and development type of research. The developmental processes involved the design, development and validation of a hybrid active learning strategy (HALS) for secondary schools in Nigeria. The package was developed in accordance with Dick and Carey (2006) instructional model. The target population for validating the HALS package were seven experts altogether for both the initial version 1.0 and the modified version 2.0. There were three physics education experts, two computer education experts and two educational technology experts. These experts were selected on the basis of their experience and versatility in their areas of specialization and their capability in validation. Also ten students were sampled for the personalized validation

and forty students sampled from two schools for the group validation, using random sampling technique and table of random numbers. The instruments used for the validation of the HALS package are the subject content, computer expert and educational technology expert validation questionnaires as well as the student response questionnaire. Other instruments included the students' interview protocol and the Written Concept Test (WCT) for direct current electricity developed by the researchers. These instruments were validated by the relevant experts and necessary corrections made before the administration.

The WCT comprised 25-multiple choice items on the concept of direct current electricity. Twenty items had four options, A to D with only one correct answer while five items required students to give reasons in order to elicit their full understanding. This instrument was used to find out the students' understanding of DCEC and hence, their performance level when taught DCEC using HALS. In order to ensure that relevant and appropriate items were included in the instrument, the test development process was followed. This included developing WCT after a careful study of the direct current electricity concepts in the Nigerian Senior Secondary School Physics Curriculum. Also, the WAEC Chief Examiners' reports (2005-2013) in physics specifically on areas that students find difficult to answer on electricity furnished the researchers with relevant information to guide the construction of the items. Thereafter, a scheme of work covering the concepts to be taught was prepared, the objectives and activities to be achieved were outlined, a table of specifications developed which embraced the content areas and the objectives. In order to analyse the effectiveness of the test questions, the item difficulty index (P) and the item discrimination index (D) of the instrument was calculated using 40 SS2 physics students that were not part of the study sample, but found to be equivalent in all respect to the students for the main study. The individual item difficulty indices for WCT instrument were within the range of 0.35 to 0.50 with an average difficulty index of 0.42 while the individual item discrimination indices were within the range of 0.30 to 0.80 with an average discrimination index of 0.52. The content validity was established using four experts, one test and measurement expert and three physics educationists. All the experts adjudged the instrument and agreed that the items were comprehensive, adequate and clear. Their independent observations, suggestions, and corrections were incorporated into the final form of the instrument. Furthermore, to establish the reliability of WCT, the instrument was trial-tested using also SS2 physics students different from those used for the main study. The test was administered on the students only once. The analysis of the results was done using Statistical Package for Social Sciences (SPSS) software. The reliability coefficient for WCT using Cronbach Alpha method was 0.81 which was considered adequate for the study.

## **Research Procedure**

The development of the HALS package took into cognizance the direct current electricity concepts as stipulated in the Nigerian Senior Secondary School Physics Curriculum. For Research Question One, the steps involved in the development of HALS were reported. The developmental stages from the content analysis, transformation of the lesson plan components into computer instructional package using the necessary programs down to packaging were reported. In the case of Research question two, the researchers reported how the developed HALS package was validated. The report included the subject content validation, computer expert validation and educational technology expert validation. The purpose was to assess the overall quality of the HALS package in terms of the content coverage, presentation, language structure, surface features, questions and menus. Another purpose was to seek their opinions and suggestions and to confirm if HALS conforms to acceptable standards in the different fields using the instrument provided. Their suggestions, modifications and corrections were incorporated into the final package. The physics expert ascertained the adequacy of the content of the HALS with regards to the officially prescribed content of the Nigerian Senior Secondary School Physics Curriculum. The computer expert reviewed the topography, legibility, navigation and the simulation properties among others while the educational technology expert specifically noted if HALS conformed to acceptable standards in educational technology (e.g. simplicity of package, unity among illustrations, color appropriateness

and font size adequacy). These were meant to solicit comments and feedback on the quality of the HALS before its use.

Also the report included the personalized and group validations with students to inquire about the quality of the HALS package for instruction. For the personalized validation, the ten randomly selected SS11 physics students each on a separate computer were taught using HALS package after being guided to navigate through the entire package. This was carried out at one of the selected schools in Kaduna State. The school was purposively selected as it had a standard ICT laboratory with sufficient functional computers to take care of the need of the study. This stage of the validation involving observation and interview enabled the researchers to get direct feedback from the students on the use of HALS for instruction. In the group validation stage, the student's response questionnaire was administered to the forty students who were randomly selected using table of random numbers from two schools, one public and one private. The students, twenty from each school, were taught DCEC using HALS over a period of six lessons. For Research Question Three, data obtained from WCT was used. This involved the forty students for group validation and the scores generated were statistically analyzed using descriptive statistics of percentages. The following range of scores determined the performance levels: High Performance (70% - 100%), Moderate Performance (50% - 69%), Low Performance (0 – 49%). The student's individual scores were used to ascertain the performance level under which they were, by comparing their scores with the range of scores in the different performance levels as earlier stated. Also, the mean scores determined their overall performance level which was used to determine the effectiveness of HALS for direct current electricity.

## **Results and Discussion**

### **Research Question One**

What are the steps taken in the development of HALS?

The initial step in the development of HALS was to take into cognizance the direct current electricity concepts as stipulated in the Nigerian Senior Secondary School Physics Curriculum. The review of relevant literature and the need to have a student-friendly package, informed the researchers on what to consider in the development of HALS. The package took into consideration the need for:

1. A simple computer interface that is attractive to students, easy to use and operates on Windows operating system which most users are familiar with.
2. A computer-based teaching strategy that involves a combination of other strategies to make the package student-activity oriented in order to achieve the stated objectives of the physics curriculum.
3. Controls that can easily be manipulated such as clicking on command buttons to execute some actions and entering values into textboxes rather than the use of special probes.
4. A programming language like Visual Basic 6.0 as the interpreter and compiler since its syntax is relatively easy to understand, being close to normal usage and logic of English language.
5. Visual presentation of the symbols of the elements of direct current electricity as well as values in both tabular and graphical forms.
6. Demonstrations of the various concepts of direct current electricity using a commonly available Macromedia Flash player.
7. Explanations of the various concepts of direct current electricity as an integral part of the demos.

The development of HALS required the use of a personal computer or a laptop, some application software and an empty CD-Rom. In developing the instructional package, the components needed were mapped out, content of the scheme of work organized and arranged to cover six lessons which was later re-organized into six modules. The scheme of work and the planned lessons were transformed into a computer instruction package



suitable for classroom instruction. Each module included computer simulation, cooperative learning, questioning, discussion, manipulation, exploration and experimentation. As the students manipulated and explored the simulation, they followed the instructions to perform the activities and answered the questions. By so doing, they worked cooperatively. The four key elements of cooperative learning; positive interdependence, individual accountability, equal participation and simultaneous interaction referred to as PIES principles (Kagan, 2009), were embedded into the structure of HALS to increase students' active engagement. Each item in the lesson plans was presented in the package. The package was produced using Microsoft Visual Basic 6 while the demos were effected using Macromedia Director and they are played using Macromedia Flash Player. In addition, all the required controls and objects such as command buttons, textboxes, graphing controls and labels are all inherent and easily accessible from the Visual Basic 6 programming language. The package was burnt on a durable CD with an instruction manual prepared by the researchers for easy use and installation. The manual was prepared using Microsoft Word 2010 text editor. The Splash screen of HALS package is shown in Figure 1.

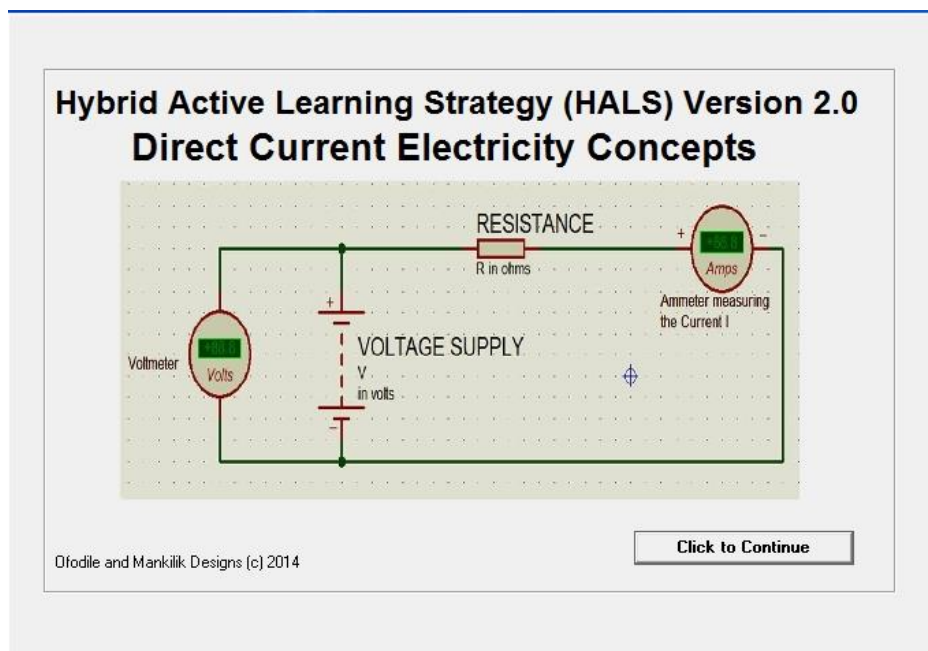

Figure 1. The splash screen of HALS simulation

## Research Question Two

How was the developed HALS package validated?

### *Subject Content Validation*

The subject content validation questionnaire was administered on four physics experts who positively responded to every question in the instrument. The experts perceived the HALS package as generally very educative, comprehensive and of good quality. They also viewed the objectives, contents and materials as adequate in exposing the students to the concept of direct current electricity and the methodology as student-centred. However, the major modifications arising from their suggestions were the restructuring of the package into different modules. The physics experts specifically ascertained the adequacy of the contents of the HALS with regards to the officially prescribed contents of the Nigerian Senior Secondary School Physics Curriculum. They further stated that the contents were sequentially arranged, covered appropriate materials, language suitable for the population in question, length of the entire package appropriate and instructions clear, concise, complete and easy to understand. However, some questions were restructured and some phrases modified. Their suggestions, comments and corrections were all incorporated into the package.

### *Computer Experts Validation*

The ten item instrument was administered on two computer experts who positively responded with comments. These experts viewed as adequate the topography, font size, legibility, navigation, simulation properties, packaging and the overall interface of the HALS package. Generally, they perceived the package as a unique design loaded with ingenuity in the design of instructional packages. However, one of the experts recommended that the virtual experiment panel should have an activity model tied to it rather than an independent function. While the other expert recommended an increase in some of the text fonts as well as de-clustering of the graphical user interface (GUI). These were noted and incorporated into the design. Both experts viewed the package as user- friendly and of good quality.

### *Educational Technology Expert Validation*

The two educational technology experts, through the eight item instrument administered on them, noted that HALS conformed to acceptable standards in educational technology. Specifically, this was done with emphasis on key concepts, simplicity of the pages in the package, unity among illustrations, color appropriateness and font size adequacy. In addition, the educational technology experts noted that the package is detailed in information, critical in analysis and provides a lot of insight and mental activities. One of the experts suggested that the font size of some text should be increased as well as a particular page of the package to be more simplified. While the other expert noted that some specific background colours do not contrast very well and should be changed. The recommendations were effected.

The comments and feedbacks of all these experts were used to strengthen the quality of HALS package.

### *Personalized Validation*

Subsequent to the successful completion of the expert validation, the ten randomly selected SS11 physics students, after being taught using HALS and guided to navigate through the entire package, were orally interviewed. They were evaluated using the Students' Interview Protocol and the criteria used were clarity, interactivity, ease of navigation and instructions as well as the overall view of the package among others. The students attested to the clarity of the expressions used in the HALS package. They stated that the language used in the instructional package is clear and unambiguous. They claimed that the package enabled them to learn and understand very fast on their own following the clear instructions. They further stated that the way information were presented in the package from simple to complex was adequate. The students declared that the package is highly interactive as they were engaged all through the activities with the teacher as a facilitator. In addition, they explained that the package provided a lot of insight and mental activities for them. In terms of navigation, they claimed that it was easy for them to navigate from one module to another. The students believed that it is better for them to use the computer simulation package than the method used by their teacher. They emphasized that they do not need the teacher to use the package except as a guide. On the contrary, the students observed that in some of the computers especially desktops, there was a malfunctioning of the Back/Exit key. This was traced to the installation and was noted for correction. Also some animations needed colour enhancement as viewed by the students. The students did not observe any major problem associated with the use of the package except for the ones mentioned. From observations, the researchers noted that a clear introduction of the HALS icon will make it easy for the students to launch into the splash screen boosting navigation. Also, this stage of validation has established the need to have backup power supply (generator) and uninterrupted power system (UPS) for computers to provide uninterrupted power when there is an outage in the public power supply system. After the personalized validation, the HALS package was modified based on the outcome of the researchers' observation of the students during instruction as well as the students observations, comments and suggestions from the oral interview that were adequately noted.

*Group Validation*

This stage tested the effectiveness of the modifications made after the personalized validation and to see its adequacy in group instruction. After the students had been taken through the package, they responded to the statements regarding the content, language structure, navigation, interactivity, colour usage, presentation format, overall interface and general perception of the HALS instruction. This was done using the Students' Response Questionnaire. The analyses of the results obtained from their responses are shown in Table 1.

**Table1. Analysis of students' responses to students' response questionnaire for group validation**

S/N	Items	Total Positive Response		Total Negative Response		Overall Total Response
		n	%	n	%	
1	Content	35	87.5	5	12.5	
2	Language Structure/Instructions	37	92.5	3	7.5	
3	Navigation	37	92.5	3	7.5	
4	Interactivity	38	95.0	2	5.0	
5	Colour Usage	36	90.0	4	10.0	
6	Presentation Format(Organization	38	95.0	2	5.0	
7	Overall Interface	36	90.0	4	10.0	
8	General Perception	38	95.0	2	5.0	
	<b>Total</b>	<b>295</b>		<b>25</b>		<b>320</b>
	<b>Mean % Response</b>		<b>92.2</b>		<b>7.8</b>	

The analysis in Table 1 showed that the total positive response of the students was 92.2% while the total negative response was 7.8%. This implies that the students generally responded positively to the statements regarding the items, while only a few held negative opinion. The students were satisfied with the well-organized content and highly interactive nature of the package allowing them to fully participate in the lessons. Also they proposed that the package is good and should be encouraged for the benefit of Nigerian students especially those preparing for external examinations. In addition they attested to the captivating nature of the package as a result of the way the information was presented. Generally, the students perceived the HALS package as educative, effective, motivating, self-explanatory and user friendly. Furthermore, the findings showed that most of the students were satisfied with the package and favoured its use to any other method of instruction. This is as a result of the fact that the observations, comments and suggestions made by the experts and from the personalized validation were incorporated into the package to strengthen the quality.



### Research Question Three

What are the performance levels of students in DCEC when taught using HALS?

The performance levels of students in both school types generally indicated high performances. Over 80% of students in both schools were in the high performance level. The result is presented in Table 2.

**Table 2. Performance levels of students in the WCT for DCEC**

School	No of Students n	Mean $\bar{X}$	Students in the Different Performance Levels					
			High 70% - 100%		Moderate 50% - 69%		Low 0 - 49%	
			n	%	n	%	n	%
Public	20	72.70	16	80	4	20	-	-
Private	20	73.85	17	85	3	15	-	-

The analysis in Table 2 showed that the public school recorded a group average of 72.70% while the private school recorded an average of 73.85%. This shows that the levels of performance of students in both schools were generally the same and high. Furthermore, only four out of the twenty students in the public school and three out of twenty in private school were in the moderate performance level. In both schools, none of the students was in the low performance level. This implies that the HALS instruction which the students were exposed to was effective and improved their understanding of DCEC leading to the high performance level recorded. The findings of this study are in line with the findings of Fakomogbon, Shittu, Omiola and Morakinyo (2012) which indicated that a web-based instructional (WBI) package in basic technology enhanced students' performance.

### Conclusion and Recommendations

This study provides evidence that HALS was developed to involve a combination of strategies of computer simulation, cooperative learning, questioning, class discussion, manipulation, exploration and experimentation that made the package student-activity oriented in order to achieve the stated objectives of the physics curriculum. The results obtained showed that the contents of HALS with regards to the officially prescribed contents of the Nigerian Senior Secondary School Physics Curriculum were adequate and sequentially arranged. The findings of this study also indicated that the developed HALS package conforms to the acceptable standards in computer and educational technology fields. The results further showed that the performance level of students when exposed to HALS instruction were very good and high. In view of this, the sustenance of students' participation in science and technology can be achieved by the adoption of HALS which encourages and motivates the students to practice and apply the scientific knowledge gained to new situation by making use of the process skills of science. Based on the findings of this study, it is recommended that Hybrid Active Learning Strategy (HALS) should be used in secondary schools for the teaching of direct current electricity concepts (DCEC) in physics to promote students' understanding of concepts. Furthermore, it is recommended that HALS should be expanded to include other aspects of physics and even extended to other science subjects. Also physics teachers should endeavour to use activity oriented mode of instructions like HALS in order to enable students participate actively in learning for better understanding. In addition, Nigerian secondary schools should be equipped with technologies like computers in conjunction with relevant computer assisted instructional

packages such as HALS that will be fully accessible to the students to enhance learning and improve performance.

## References

- Abubakar, S. (2012). Role of physics education for technological development for employment and self productivity in Nigeria. *Journal of Educational and social Research*, 2(10), 166-170.
- Adegoke, B. A. (2011). Effects of multimedia instruction on senior secondary school students' achievement in physics. *European Journal of Educational Studies*, 3(3), 537-550.
- Adeyemo, S. A. (2010). Students ability level and their competence in problem solving task in physics. *International Journal of Education Research and Technology*, 1(2), 35-47.
- Afolabi, F., & Akinbobola, A. O. (2009). Constructivist problem- based learning technique and the academic achievement of physics students with low ability level in Nigerian secondary schools. *Eurasian Journal of Physics and Chemistry Education*, 1(1), 45-51.
- Akinbobola, A. O. (2009). Enhancing students' attitude towards Nigerian senior secondary school physics through the use of cooperative competitive and individualistic learning strategies. *Australian Journal of Teacher Education*, 34(1), 1-9.
- Akinbobola, A. O., & Afolabi, F. (2010). Constructivist practices through guided discovery approach: The effect on students' cognitive achievement in Nigerian senior secondary school physics. *Eurasian Journal of Physics and Chemistry Education*, 2(1), 16-25.
- Baser, M., & Durmus, S. (2010). The effectiveness of computer supported versus real laboratory inquiry learning environments on the understanding of direct current electricity among pre-service elementary school teachers. *Eurasia Journal of Mathematics, Science & Technology*, 6(1), 47-61.
- Bello, T. O (2011). Effects of group instructional strategy on students' performance in selected physics concepts. *The African Symposium*, 11(1), 71-79.
- Dick, W., & Carey, L. (2006). *Instructional design model*. Retrieved from <http://www.jessegentile.com/---/Dick%20&%20...html>
- Erinosho, S. Y, (2013). How do students perceive the difficulty of physics in secondary school? An exploratory study in Nigeria. *International Journal for Cross-disciplinary Subjects in Education (IJCDSE)*, 3(3), 1510-1515.
- Fakomogbon, M. A., Shittu, A. T., Omiola, M. A., & Morakinyo, O. K. (2012). Design, development and validation of a web-based instructional package for teaching ceramics concepts in basic technology for the junior secondary school students in Nigeria. *Interdisciplinary Journal of Contemporary Research in Business*, 3(10), 533-541.
- Federal Republic of Nigeria (2004). *National Policy on Education*, Lagos: NERDC.
- Gambari, I. A., & Yusuf, M. O. (2014). Development and Validation of computer instructional package on physics for secondary schools in Nigeria. *Educational Research International*, 3(1), 112-130.
- Kaduna State Ministry of Education, KSMOE, (2008). *Kaduna State Education Sector Analysis*. Kaduna: Author
- Kagan, S. (2009). *Cooperative Learning: PIES*. Retrieved from <http://mset.rst2.edu/ portfolio /.../Cooperative%20learning/PIES.htm>
- Okorie, E. U. (2014). Development and validation of teacher-made instructional software package for teaching chemical bonding in secondary schools. *Journal of Education and Practice*, 5(22), 28-33.
- Oyelekan, O. S., & Olorundare, A. S. (2009). Development and validation of a computer instructional package on electrochemistry for secondary schools in Nigeria. *International Journal of Education and Development using Information and Communication Technology (IJEDICT)*, 5(2), 88-104.

- Udoh, O. A. (2012). Refocusing physics education in Nigeria: Issues and challenges in teacher education. *Mediterranean Center of Social and Educational Research*, 3(13), 11-19.
- WAEC. (2005-2013). *The West African Examination Council: Chief examiners' reports (Nigeria)*. Lagos, Nigeria: Author.
- WAEC. (2008). *Executive summary of entries, results and chief examiners report on West African Senior Secondary School Certificate Examination (WASSCE) conducted in Nigeria*. Lagos, Nigeria: Author.
- Zacharia, Z. C., & Olympiou, G. (2010). Physical versus virtual manipulative experimentation in physics learning. *Learning and Instruction*, 21(3), 317-331.